



**S 1000 RR 2019-2025**  
**M 1000 RR 2019-2024**

# FITTING INSTRUCTIONS

TO BE FITTED BY A QUALIFIED TECHNICIAN

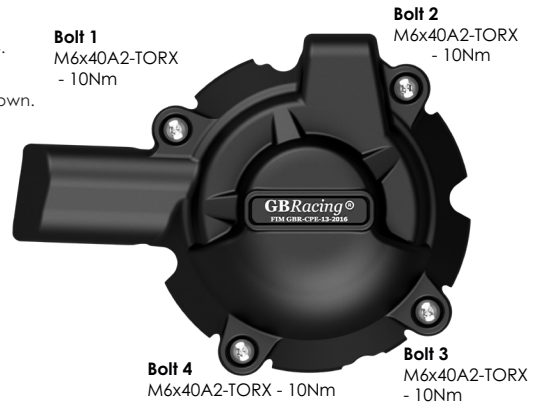
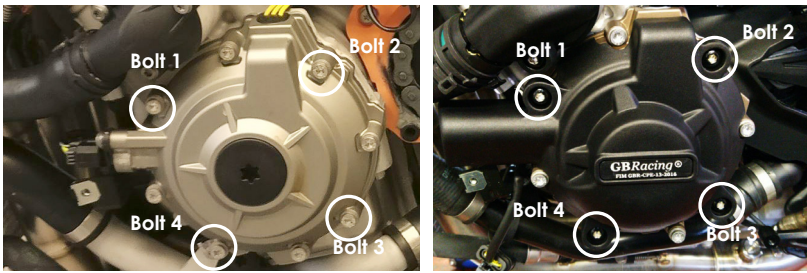


**THIS SHEET INCLUDES FITTING INSTRUCTIONS FOR THE FOLLOWING PARTS:**

Secondary Alternator Cover Part No. EC-S1000RR-2019-1-GBR / Secondary Alternator Cover Part No. EC-S1000RR-2025-1-GBR  
 Secondary Clutch Cover Part No. EC-S1000RR-2019-2-GBR / Secondary Pulse Cover Part No. EC-S1000RR-2019-3-GBR  
 Secondary Thermostat Cover Part No. EC-S1000RR-2019-5-GBR / Secondary Thermostat Cover Part No. EC-S1000RR-2019-7-GBR (special race part only)  
 Bullet Frame Sliders Part No. FS-S1000RR-2019-R & FS-S1000RR-2019-S / Frame Protector Set Part No. FP-S1000RR-2019-SET-GBR /

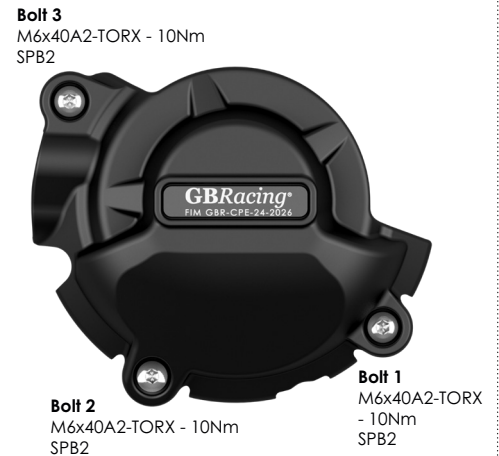
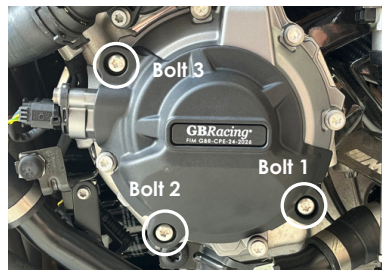
**SECONDARY ALTERNATOR COVER – PART NO. EC-S1000RR-2019-1-GBR**

- 1 Remove 4 existing stretch bolts from the stock Alternator cover, shown as position Bolt 1, 2, 3 & 4.
- 2 Place the Secondary Alternator Cover over the stock cover.
- 3 Assemble 4 replacement stainless steel M6X40A2 TORX bolts loosely in the correct position as shown.
- 4 Tighten bolts to a Torque of 10Nm. DO NOT OVERTIGHTEN.



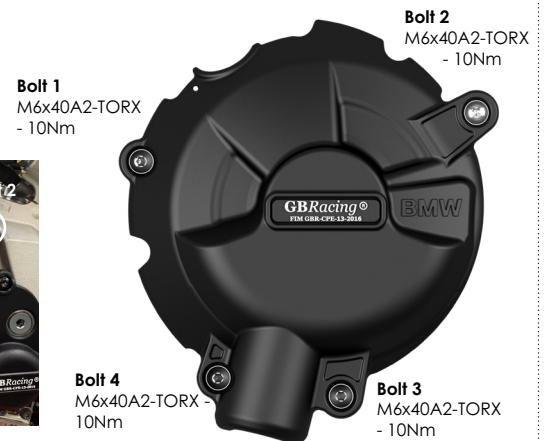
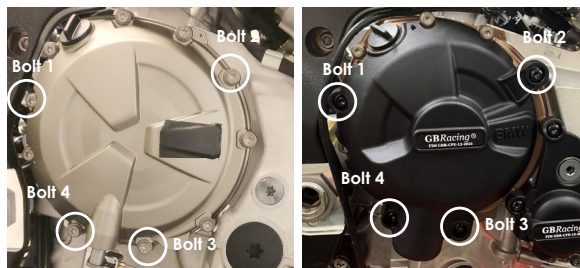
**SECONDARY ALTERNATOR COVER – PART NO. EC-S1000RR-2025-1-GBR**

- 1 Remove fairing.
- 2 Remove 3 existing bolts from the stock Alternator cover, shown as position Bolt 1, 2 & 3.
- 3 Place the Secondary Alternator Cover over the stock cover.
- 4 Assemble 3 replacement stainless steel M6x40-TORX bolts loosely in the correct position as shown.
- 5 Tighten bolts to a Torque of 10Nm. DO NOT OVERTIGHTEN.
- 6 Refit fairing.



**SECONDARY CLUTCH COVER – PART NO. EC-S1000RR-2019-2-GBR**

- 1 Remove Upper fairing.
- 2 Remove 4 existing bolts from the stock clutch cover, shown as position Bolt 1, 2, 3 & 4.
- 3 Place the Secondary Clutch Cover over the stock cover.
- 4 Assemble 4 replacement M6X40A2 TORX bolts, loosely in the correct position as shown.
- 5 Tighten bolts to a Torque of 10Nm. DO NOT OVERTIGHTEN.
- 6 Re-Fit Upper Fairing.





**S 1000 RR 2019-2025**  
**M 1000 RR 2019-2024**

# FITTING INSTRUCTIONS

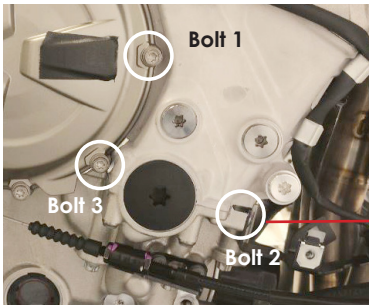
TO BE FITTED BY A QUALIFIED TECHNICIAN



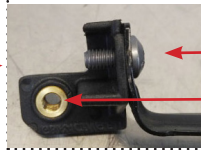
## SECONDARY PULSE COVER – PART NO. EC-S1000RR-2019-3-GBR

- 1 Remove 3 existing bolts indicated in **Fig 1**.
- 2 Fit GBRacing fixing bracket to existing bracket as shown in **Fig 2**.
- 3 Fixing bracket is fitted to engine using existing clutch cable mount.
- 4 Place the Secondary Pulse Cover over these bolt positions in **Fig 1**.
- 5 Assemble 2 replacement M6X40A2 TORX bolts, loosely in the correct position as shown at bolt positions 1 & 3.
- 6 Bolt 2 M6X30A2 TORX will secure to the fixing bracket as indicated in **Fig 2 & 3**.
- 7 Tighten bolts to a Torque of 10Nm. DO NOT OVERTIGHTEN.

**Fig 1.**

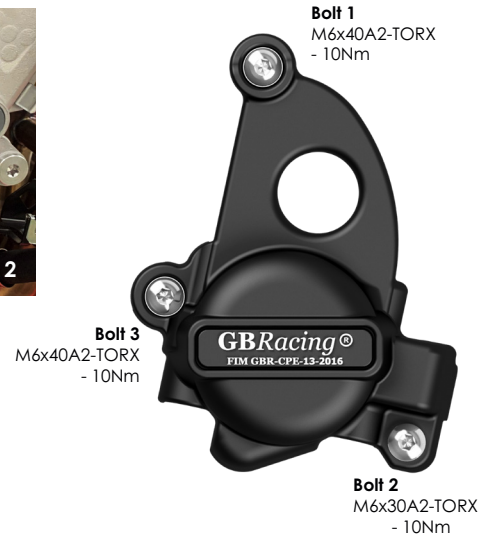
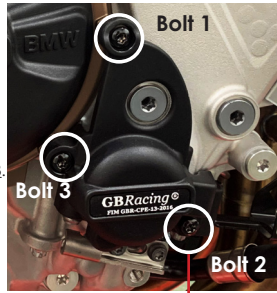


**Fig 2.**  
Fixing Bracket (EC-S1000RR-2019-3-FB-GBR) for Bolt 2



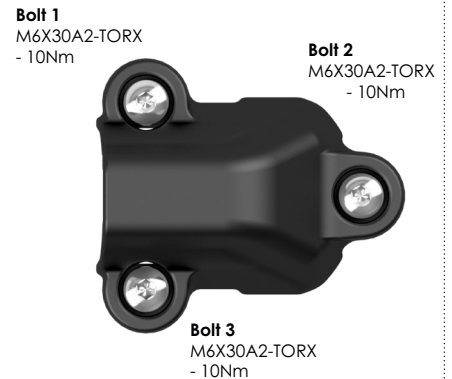
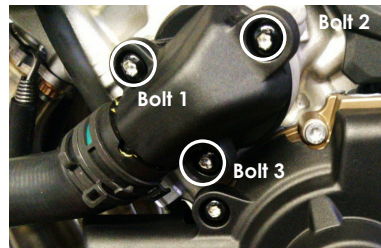
Use OE mounting bolt here  
 Bolt 2 M6X30A2 mounting point

**Fig 3.**



## SECONDARY THERMOSTAT COVER PART NO. EC-S1000RR-2019-5-GBR

- 1 Fitting requires a COLD engine.
- 2 Decompress the system before loosening existing stock bolts.
- 3 Have all 3 Replacement Bolts to hand before removing existing stock bolts.
- 4 Loosen bottom fairing bolt to enable access to the Thermostat Cover.
- 5 Remove 3 existing bolts from the stock Thermostat Cover shown as bolt positions 1, 2 & 3
- 6 Place the Thermostat Cover over the stock cover.
- 7 Assemble 3 replacement bolts, loosely in the correct position as shown.
- 8 Tighten bolts to a Torque of 10Nm. DO NOT OVERTIGHTEN.
- 9 Tighten bottom fairing bolt.
- 10 Check coolant level & top up if necessary before starting engine.



## ENGINE COVER SET: EC-S1000RR-2019-SET-GBR:

EC-S1000RR-2019-1-GBR, EC-S1000RR-2019-2-GBR, EC-S1000RR-2019-3-GBR, EC-S1000RR-2019-3-FB-GBR, EC-S1000RR-2019-5-GBR

### **BULLET FRAME SLIDER SET - RACE:** PART NO. FS-S1000RR-2019-R:

- 1 Remove fairing.
- 2 Remove Front Engine mount Bolt.
- 3 Assemble bolt through the aluminium bush into correct position.
- 4 Depending on Year check before Drilling Fairing.
- 5 Tighten to 40Nm torque.
- 6 Replace fairing.
- 7 Slide bullet moulding onto aluminium bush.

### LEFT HAND SIDE - RACE PART NO. FS-S1000RR-2019-LHS-R



CPM-3  
 CPB-10-20  
 M10x55



### RIGHT HAND SIDE - RACE PART NO. FS-S1000RR-2019-RHS-R



CPM-3  
 CPB-10-20  
 M10x55



### **BULLET FRAME SLIDER SET - STREET:** PART NO. FS-S1000RR-2019-S:

- 1 Remove fairing.
- 2 Remove Front Engine mount Bolt.
- 3 Assemble bolt through the aluminium bush into correct position.
- 4 Depending on Year check before Drilling Fairing.
- 5 Tighten to 40Nm torque.
- 6 Replace fairing.
- 7 Slide bullet moulding onto aluminium bush.

### LEFT HAND SIDE - STREET PART NO. FS-S1000RR-2019-LHS-S

CPM-3  
 CPB-10-40  
 M10x55



### RIGHT HAND SIDE - STREET PART NO. FS-S1000RR-2019-RHS-S

CPM-3  
 CPB-10-35  
 M10x55





S 1000 RR 2019-2025  
M 1000 RR 2019-2024

# FITTING INSTRUCTIONS

TO BE FITTED BY A QUALIFIED TECHNICIAN



## FRAME PROTECTOR SET: PART NO. FP-S1000RR-2019-SET-GBR:

### LEFT HAND SIDE FRAME PROTECTOR PART NO. FP-S1000RR-2019-LHS-GBR

- 1 Remove fairing.
- 2 Hold left hand frame protector in correct position and mark chassis.
- 3 Drill and tap chassis in correct locations.
- 4 Mount frame protector.
- 5 Replace fairing.



### RIGHT HAND SIDE FRAME PROTECTOR PART NO. FP-S1000RR-2019-RHS-GBR

- 1 Remove fairing.
- 2 Drill and tap chassis in correct locations IF REQUIRED.
- 3 Fix frame protector to chassis.
- 3 Replace fairing.



## **SPECIAL RACE PART ONLY - NOT TO FIT ON A ROAD BIKE (No bolts supplied)**

### SECONDARY THERMOSTAT COVER PART NO. EC-S1000RR-2019-7-GBR

- 1 Fitting requires a COLD engine.
- 2 Decompress the system before loosening existing stock bolts.
- 3 Have all 3 Replacement Bolts to hand (bolts not supplied) before removing existing stock bolts.
- 4 Loosen bottom fairing bolt to enable access to the thermostat cover.
- 5 Remove 3 existing bolts from the thermostat cover shown as bolt positions 1, 2 & 3
- 6 Place the thermostat cover over the stock cover.
- 7 Assemble 3 replacement bolts (not supplied), loosely in the correct position as shown.
- 8 Tighten bolts to a Torque of 10Nm.  
DO NOT OVERTIGHTEN.
- 9 Tighten bottom fairing bolt.
- 10 Check coolant level & top up if necessary before starting engine.

**Bolt Length required: 3 x 30mm - 10Nm**  
(Bolts not supplied)

