

THIS SHEET INCLUDES FITTING INSTRUCTIONS FOR THE FOLLOWING PARTS:

Secondary Alternator Cover Part No. EC-MT09-2021-1-GBR / Secondary Clutch Cover Part No. EC-MT09-2021-2-GBR /
Secondary Pulse Cover Part No. EC-MT09-2021-3-GBR / Secondary Water Pump Cover Part No. EC-MT09-2021-5-GBR
Bullet Frame Slider Set Part No. FS-MT09-2021-S / XSR900 2022-2024 & XSR900 GP 2024 MODELS ONLY: Frame Sliders STREET - Part No. FS-XSR900-2022-S

SECONDARY ALTERNATOR COVER – PART NO. EC-MT09-2021-1-GBR

- 1 Remove 4 existing bolts from the stock Alternator cover, shown as position Bolts 1, 2, 3 & 4.
- 3 Place the Secondary Alternator Cover over the stock cover.
- 4 Assemble 4 replacement bolts loosely in the correct position as shown.
- 5 Tighten bolts to a Torque of 10Nm as per Manufacturer's recommendations. DO NOT OVERTIGHTEN.

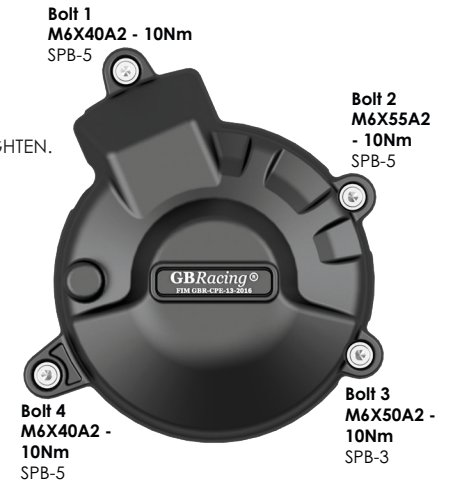
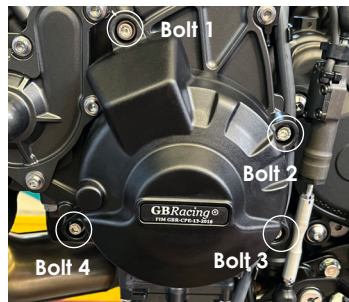
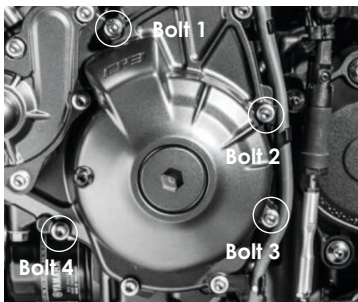

SECONDARY CLUTCH COVER – PART NO. EC-MT09-2021-2-GBR

- 1 Please remove plastic dust cover before fitting the GBRacing cover – remove the bolts from the plastic dust cover. Put the left and top bolts back in their original locations (minus dust cover) See Fig.1.
- 2 Remove 4 existing bolts from the stock clutch cover, shown as position Bolts 1, 2, 3 & 4.
- 3 Place the Secondary Clutch Cover over the stock cover.
- 4 Assemble 4 replacement bolts loosely in the correct position as shown.
- 5 Tighten bolts to a Torque of 10Nm as per Manufacturer's recommendations. DO NOT OVERTIGHTEN.

Fig 1

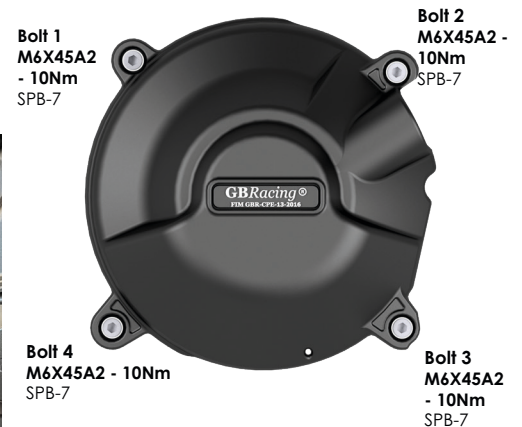
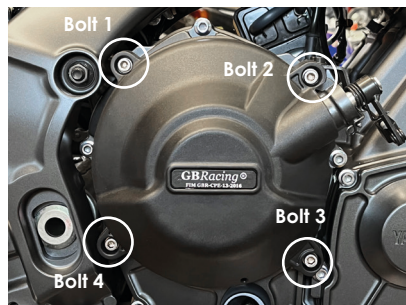

SECONDARY PULSE COVER – PART NO. EC-MT09-2021-3-GBR

- 1 Remove the 4 standard bolts
- 2 Place the secondary pulse cover against the standard cover using the 4 supplied bolts.
- 3 Tighten all 4 bolts to 10nm as per manufacturer's recommendations DO NOT OVERTIGHTEN

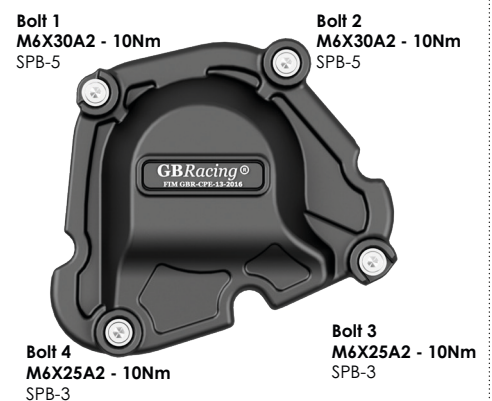
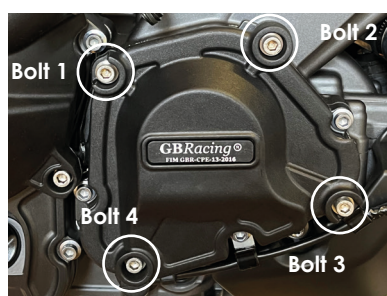
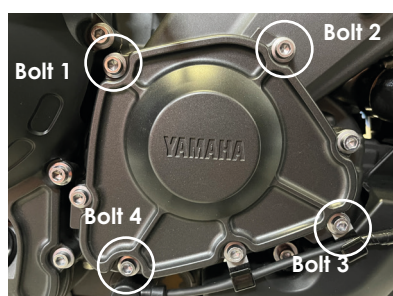

SECONDARY WATER PUMP COVER PART NO. EC-MT09-2021-5-GBR

- 1 Fitting requires a COLD engine.
- 2 Ensure radiator cap is firmly on. Do not loosen.
- 3 Remove Bolt 1 & 3 before removing Bolt 2. Once bolt 2 is removed you will lose approx 6 drops of coolant and it will not drip anymore. Follow **Fig 2**, to make sure that the supplied copper washers are in the correct positions.
- 4 Insert **Bolt 2** with the washers into correct hole and hand-tighten - See **Fig 1**.
- 5 Then insert Bolts 1 & 3 and tighten to correct torque setting 10Nm. **DO NOT OVERTIGHTEN**
- 6 Check the water level as per the manufacturer's recommendations.

Fig. 1

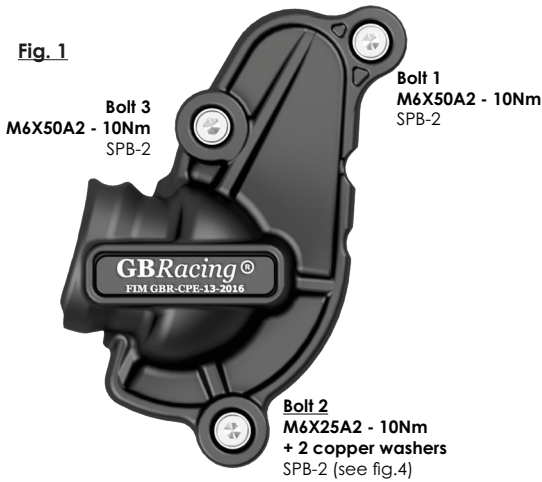
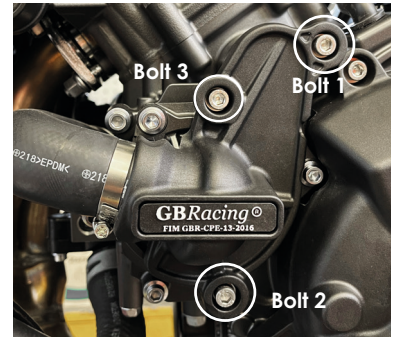
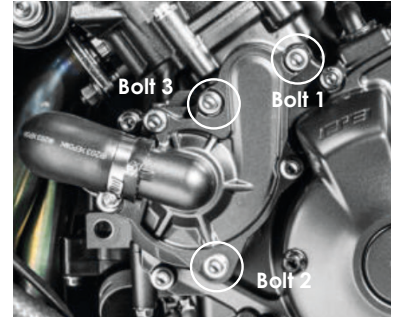
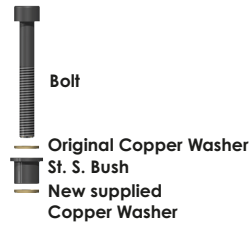

Fig. 2



SET: Engine Cover Set: EC-MT09-2021-SET-GBR

Secondary Alternator Cover Part No. EC-MT09-2021-1-GBR / Secondary Clutch Cover Part No. EC-MT09-2021-2-GBR /
Secondary Pulse Cover Part No. EC-MT09-2021-3-GBR / Secondary Water Pump Cover Part No. EC-MT09-2021-5-GBR

**BULLET FRAME SLIDER SET: BOTH SIDES
PART NO. FS-MT09-2021-S**

- 1 Remove upper engine mounting bolt.
- 2 Assemble bolt through the aluminium bush into correct position.
- 3 Tighten to 60NM torque.
- 4 Slide bullet moulding onto aluminium bush.
- 5 Screw M6 bolt through moulding hand tight.

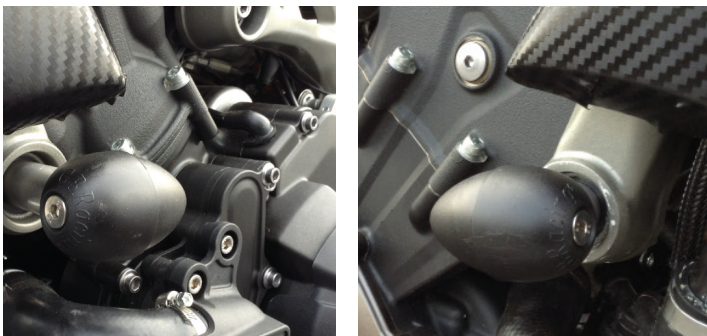

LEFT HAND SIDE

FS-MT09-2021-LHS-S



RIGHT HAND SIDE

FS-MT09-2021-RHS-S



REPLACEMENT BULLET MOULDED PART

Part No. CPM-3

or

CPM-3-GP

This essentially replaces the CPM-3 puck, allowing a GoPro camera mount to be attached to the bike using our mounting system.



FIT XSR900 2022-2023 & XSR900 GP 2024 MODELS ONLY: BULLET FRAME SLIDER SET - Part No. FS-XSR900-2022-S:

**BULLET FRAME SLIDER - LEFT HAND SIDE - STREET
- PART NO. FS-XSR900-2022-LHS-S**



INSTRUCTIONS FOR THESE PARTS:

1. Remove front engine mounting bolt with washer.
NOTE: On the RHS do not remove the conical washer.
2. Assemble bolt through the aluminium bush into correct position.

**BULLET FRAME SLIDER - RIGHT HAND SIDE - STREET
- PART NO. FS-XSR900-2022-RHS-S**



3. Tighten to 40NM torque.
4. Slide bullet moulding onto aluminium bush.
5. Screw M6 bolt into front of bullet moulding hand tight.