

**THIS SHEET INCLUDES FITTING INSTRUCTIONS FOR THE FOLLOWING PARTS:**

Secondary Alternator Cover Part No. EC-R1-2007-1-GBR / Secondary Clutch Cover Part No. EC-FZ8-2010-2-GBR /  
 Secondary Pulse Cover Part No. EC-FZ8-2010-3-GBR / Secondary Crank Cover Part No. EC-FZ8-2010-4-GBR /

**SECONDARY ALTERNATOR COVER**  
**PART NO. EC-R1-2007-1-GBR**

- 1 Remove the Belly Pan (Not Applicable for FZ8/FZ1).
- 2 Remove 3 off existing bolts on the stock aluminium Alternator cover, corresponding to the STOCK Secondary Engine Alternator Cover. Shown as bolt positions 1, 2 & 3.  
 Note: Retain the steel bracket found at Bolt Position 1, in place. (If bracket is not present use M6 washers to space accordingly).
- 3 Place the Secondary Engine Alternator cover over the stock aluminium alternator cover. Loosely screw down Bolt 1, lining up the Steel Bracket, then the remaining Bolts as supplied, M6x35mm Cap Head Bolts.
- 4 Tighten all 3 bolts to a torque of 10 N/m as per Manufacturer's recommendations. **DO NOT OVERTIGHTEN**
- 5 Refit the Belly Pan.

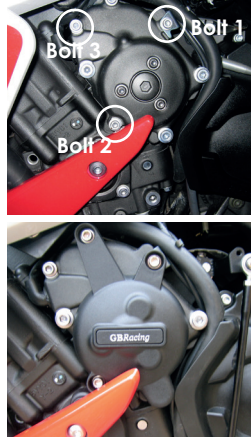

**SECONDARY CLUTCH COVER**  
**PART NO. EC-FZ8-2010-2-GBR**

- 1 Remove 4 existing bolts from the stock pulse cover, shown as position Bolt 1, 2, 3 & 4.
- 2 Place the Secondary Clutch Cover over the stock cover.
- 3 Assemble 4 replacement M6x45, loosely in the correct position as shown.
- 4 Tighten bolts to a Torque of 10Nm as per Manufacturer's recommendations. **DO NOT OVERTIGHTEN.**

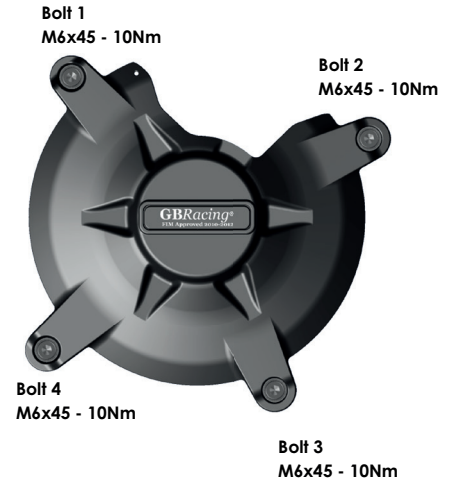
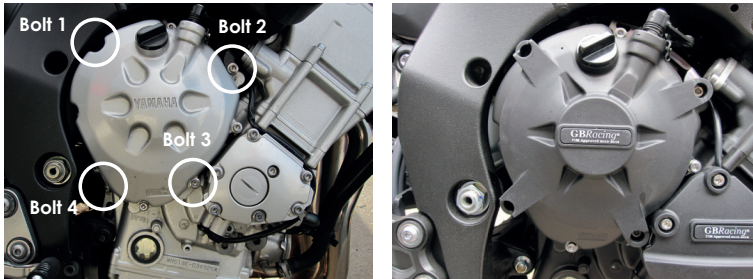

**SECONDARY PULSE COVER**  
**PART NO. EC-FZ8-2010-3-GBR**

- 1 Remove 3 off existing bolts on the stock aluminium pulse cover, corresponding to the Secondary Pulse Cover. Shown as bolt positions 1, 2, & 3.
- 2 Place the Secondary Engine Pulse Cover over the stock aluminium pulse cover. Loosely screw down bolts 1, 2, & 3 using the supplied M6x25mm bolts.
- 3 Tighten bolts to a Torque of 10Nm as per manufacturers recommendations. **DO NOT OVERTIGHTEN.**

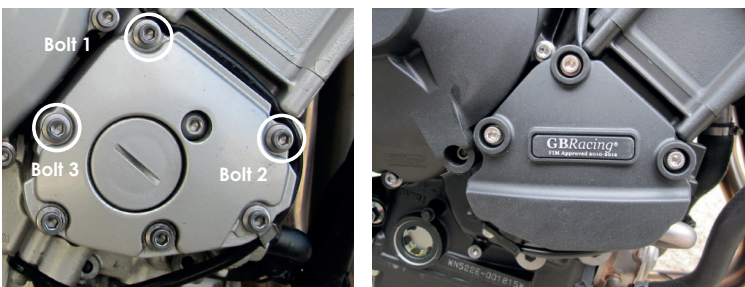

**SECONDARY CRANK COVER**  
**PART NO. EC-FZ8-2010-4-GBR**

- 1 Remove 2 existing bolts from the stock crank cover, shown as position Bolt 1 & 2.
- 2 Place the Secondary Pulse Cover over the stock cover.
- 3 Assemble 2 replacement bolts loosely in the correct position as shown.
- 4 Tighten bolts to a Torque of 10Nm as per manufacturers recommendations.  
DO NOT OVERTIGHTEN.

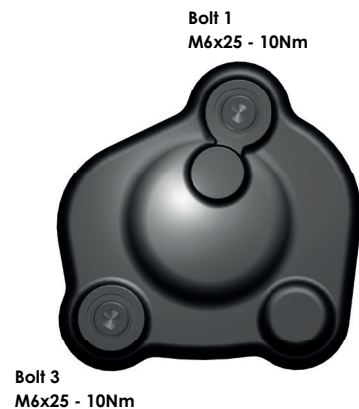
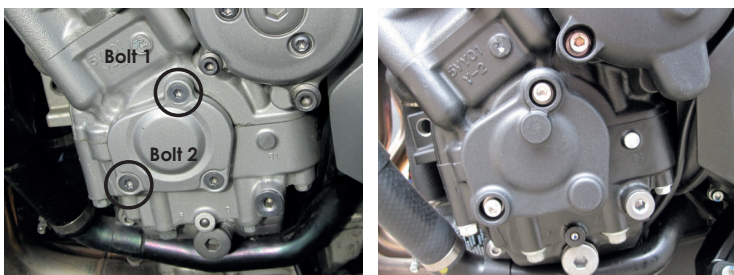

[www.GBRacing.eu](http://www.GBRacing.eu)

**Protection Bundle: CP-FZ8-2010-CS-GBR**

EC-R1-2007-1-GBR, EC-FZ8-2010-2-GBR, EC-FZ8-2010-3-GBR, EC-FZ8-2010-4-GBR, CGA10-GBR, BA12-6-GBR-SET

**Engine Cover Set: EC-FZ8-2010-SET-GBR**

EC-R1-2007-1-GBR, EC-FZ8-2010-2-GBR, EC-FZ8-2010-3-GBR, EC-FZ8-2010-4-GBR