

THIS SHEET INCLUDES FITTING INSTRUCTIONS FOR THE FOLLOWING PARTS:

Secondary Alternator Cover Part No. EC-R1-2015-1-GBR / Secondary Clutch Cover Part No. EC-R1-2015-2-GBR /

Secondary Pulse Cover Part No. EC-R1-2015-3-GBR & EC-R1-2019-3-GBR (Extended version)

Bullet Frame Race Slider Set - STREET - Part No. FS-R1-2015-S / Bullet Frame Race Slider Set - RACE - Part No. FS-R1-2015-R / Yamaha 6mm

SECONDARY ALTERNATOR COVER – PART NO. EC-R1-2015-1-GBR

1. Remove 4 existing bolts from the stock Alternator cover, shown as position Bolt 1, 2, 3 & 4.
2. Place the Secondary Alternator Cover over the stock cover.
3. Assemble 4 replacement bolts loosely in the correct position as shown.
4. Tighten bolts to a Torque of 6Nm. DO NOT OVERTIGHTEN.

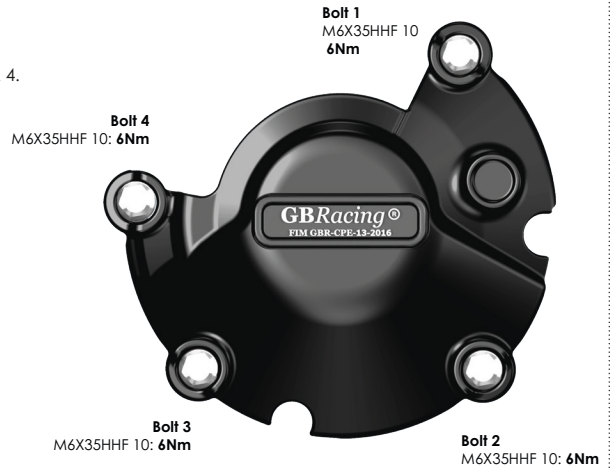
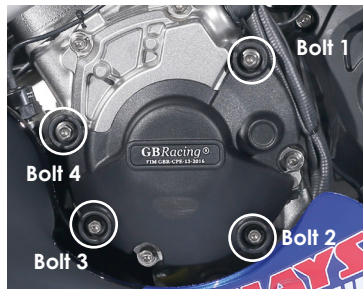
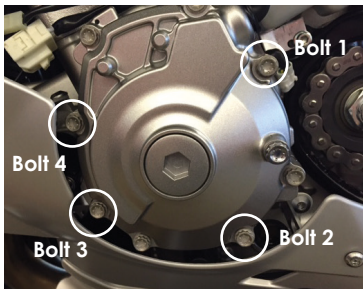

SECONDARY CLUTCH COVER – PART NO. EC-R1-2015-2-GBR

1. Remove 4 existing bolts from the stock Clutch cover, shown as position Bolt 1, 2, 3 & 4.
2. Place the Secondary Clutch Cover over the stock cover.
3. Assemble 4 replacement bolts loosely in the correct positions as shown.
4. Tighten bolts to a Torque of 6Nm. DO NOT OVERTIGHTEN.

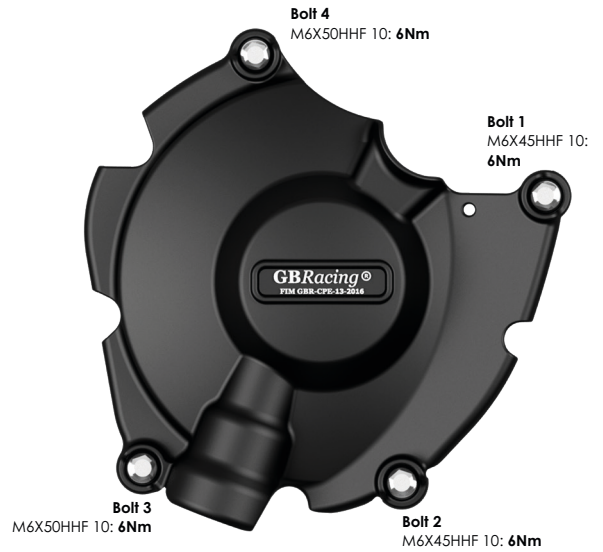
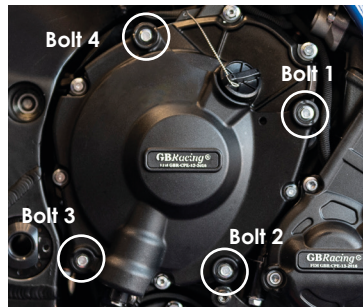
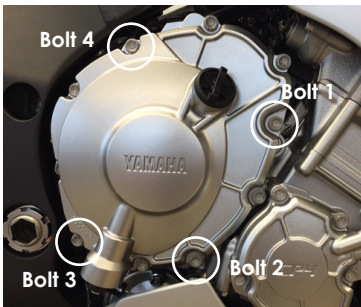

SECONDARY PULSE COVER – PART NO. EC-R1-2015-3-GBR and EC-R1-2019-3-GBR - (EXTENDED VERSION)

1. Remove 3 existing bolts from the stock pulse cover, shown as position Bolt 1, 2 & 3.
2. Place the Secondary Pulse Cover over the stock cover.
3. Assemble 3 replacement bolts loosely in the correct positions as shown.
4. Tighten bolts to a Torque of 6Nm. DO NOT OVERTIGHTEN.

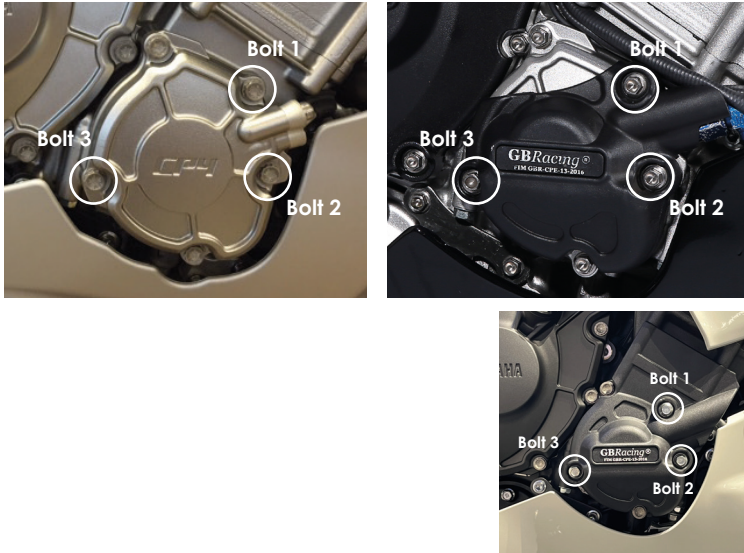

Fig.1



BULLET FRAME SLIDER - LEFT HAND SIDE - STREET - PART NO. FS-R1-2015-LHS-S

1. Remove upper engine mounting bolt, located through the fairing opening. *(ensuring that the conical OE Washer is not removed).*
2. Assemble bolt through the aluminium bush into correct position.
3. Tighten to 70NM torque.
4. Slide bullet moulding onto aluminium bush.
5. Screw M6 bolt into front of bullet moulding hand tight.



BULLET FRAME SLIDER - RIGHT HAND SIDE - STREET - PART NO. FS-R1-2015-RHS-S

1. Remove upper engine mounting bolt, located through the fairing opening. *(ensuring that the conical OE Washer is not removed).*
2. Assemble bolt through the aluminium bush into correct position.
3. Tighten to 70NM torque.
4. Slide bullet moulding onto aluminium bush.
5. Screw M6 bolt into front of bullet moulding hand tight.



BULLET FRAME SLIDER - LEFT HAND SIDE - RACE - PART NO. FS-R1-2015-LHS-R

1. Remove upper engine mounting bolt, located through the fairing opening. *(ensuring that the conical OE Washer is not removed).*
2. Assemble bolt through the aluminium bush into correct position.
3. Tighten to 70NM torque.
4. Slide bullet moulding onto aluminium bush.
5. Screw M6 bolt into front of bullet moulding hand tight.

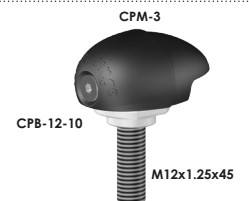

BULLET FRAME SLIDER - RIGHT HAND SIDE - RACE - PART NO. FS-R1-2015-RHS-R

1. Remove upper engine mounting bolt, located through the fairing opening. *(ensuring that the conical OE Washer is not removed).*
2. Assemble bolt through the aluminium bush into correct position.
3. Tighten to 70NM torque.
4. Slide bullet moulding onto aluminium bush.
5. Screw M6 bolt into front of bullet moulding hand tight.

