

THIS SHEET INCLUDES FITTING INSTRUCTIONS FOR THE FOLLOWING PARTS:

Secondary Clutch Cover Part No. EC-CBR650F-2014-2-GBR / Secondary Pulse Cover Part No. EC-CBR650F-2014-3-GBR

**SECONDARY CLUTCH COVER**  
**PART NO. EC-CBR650F-2014-2-GBR**

- 1 Remove 4 existing bolts from the stock Clutch cover, shown as position Bolt 1, 2, 3 & 4.
- 2 Place the Secondary Clutch Cover over the stock cover.
- 3 Assemble 4 replacement bolts loosely in the correct positions as shown.
- 4 Tighten bolts to a Torque of 10Nm as per Manufacturer's recommendations.  
DO NOT OVERTIGHTEN.

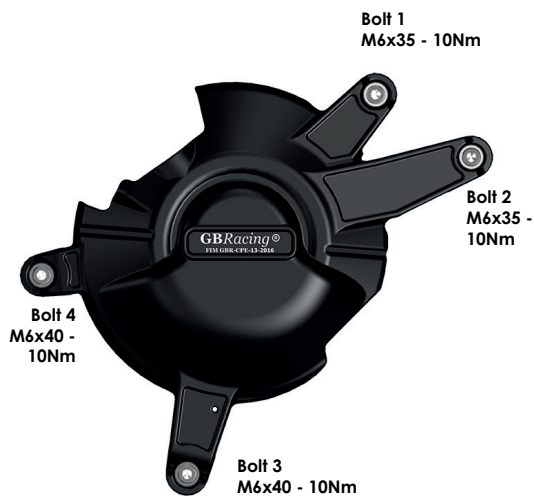
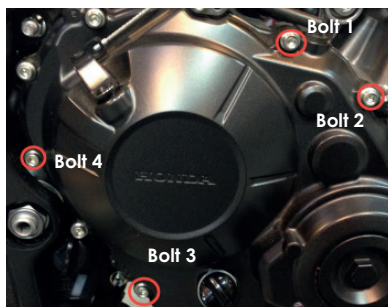

**SECONDARY PULSE COVER**  
**PART NO. EC-CBR650F-2014-3-GBR**

- 1 Remove 4 existing bolts from the stock pulse cover, shown as position Bolt 1, 2, 3 & 4.
- 2 Place the Secondary Pulse Cover over the stock cover.
- 3 Assemble 4 replacement bolts loosely in the correct positions as shown. If you have an unfaired CB650F, please use the spacer washers supplied at Bolt Position 2 & 3. Place this spacer in between the GBR engine cover and the original Honda cover in these 2 positions.
- 4 Tighten bolts to a Torque of 10Nm as per Manufacturer's recommendations.  
DO NOT OVERTIGHTEN.

