

THIS SHEET INCLUDES FITTING INSTRUCTIONS FOR THE FOLLOWING PARTS:

Secondary Alternator Cover Part No. EC-RC390-2014-1-GBR /

Secondary Clutch Cover Part No. EC-RC390-2014-2-GBR /

SECONDARY ALTERNATOR COVER PART NO. EC-RC390-2014-1-GBR

- 1 Remove Fairing Bellypan.
- 2 Remove 4 existing bolts from the stock Alternator cover, shown as position Bolt 1, 2, 3 & 4.
- 3 Place the Secondary Alternator Cover over the stock cover.
- 4 Assemble 4 replacement bolts loosely in the correct position as shown.
- 5 Tighten bolts to a Torque of 12Nm as per Manufacturer's recommendations.
DO NOT OVERTIGHTEN.
6. Replace Fairing Bellypan.

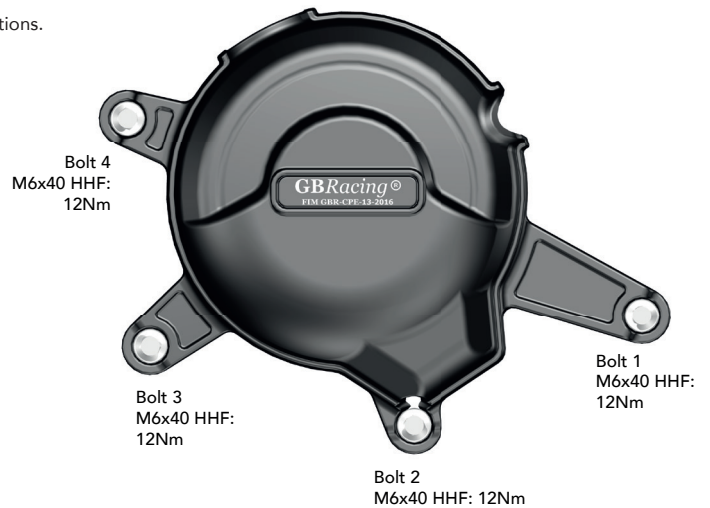
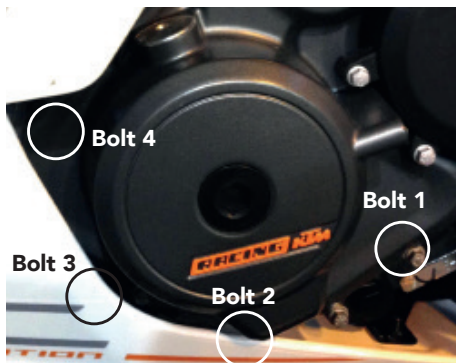
**SECONDARY CLUTCH COVER PART NO. EC-RC390-2014-2-GBR**

- 1 Remove Fairing Bellypan.
- 2 Remove 4 existing bolts from the stock Clutch cover, shown as position Bolt 1, 2, 3 & 4.
- 3 Place the Secondary Clutch Cover over the stock cover.
- 4 Assemble 4 replacement bolts loosely in the correct position as shown.
- 5 Tighten bolts to a Torque of 12Nm as per Manufacturer's recommendations. DO NOT OVERTIGHTEN.
- 6 Replace Fairing Bellypan.

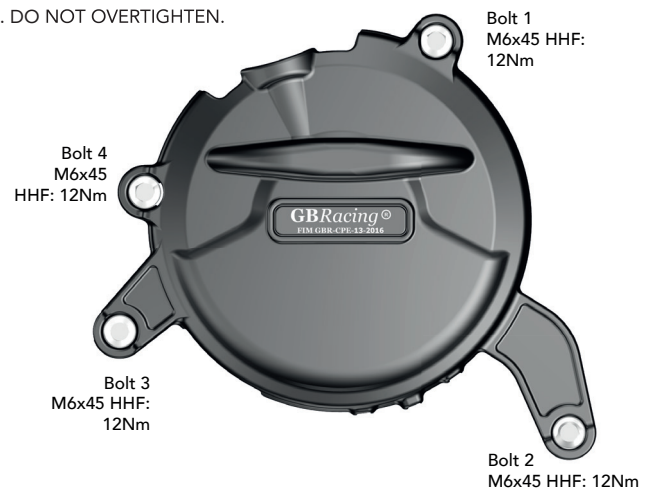
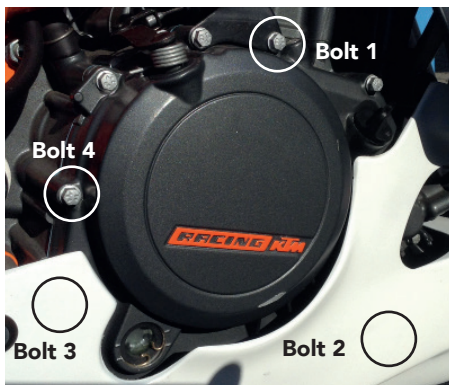
**Engine Cover Set: EC-RC390-2014-SET-GBR**

EC-RC390-2014-1-GBR, EC-RC390-2014-2-GBR