

**THIS SHEET INCLUDES FITTING INSTRUCTIONS FOR THE FOLLOWING PARTS:**

Secondary STOCK Alternator Cover Part No. EC-D675R-2013-1-GBR / Secondary Clutch Cover Part No. EC-D675R-2011-2-GBR /  
Secondary Pulse Cover Part No. EC-D675R-2013-3-GBR / Bullet Frame Slider Set RACE - D675R Model ONLY - Part No. FS-675-2013-R

**SECONDARY ALTERNATOR COVER - STOCK - PART NO. EC-D675R-2013-1-GBR**

- 1 Remove lower fairing.
- 2 Remove 4 existing bolts from the stock Alternator cover, shown as position Bolt 1, 2, 3 & 4.
- 3 Place the Secondary Alternator Cover over the stock cover.
- 4 Assemble 4 replacement bolts loosely in the correct position as shown.
- 5 Tighten bolts to a Torque of 8 Nm as per manufacturers recommendations. DO NOT OVERTIGHTEN.
- 6 Re-Fit lower Fairing.

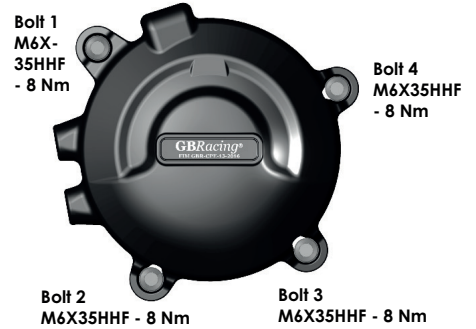

**SECONDARY CLUTCH COVER PART NO. EC-D675R-2011-2-GBR**

- 1 Remove lower fairing.
- 2 Remove 4 existing bolts from the stock Clutch cover, shown as position Bolt 1, 2, 3 & 4.
- 3 Place the Secondary Clutch Cover over the stock cover.
- 4 Assemble 4 replacement bolts loosely in the correct position as shown.
- 5 Tighten bolts to a Torque of 8 Nm as per Manufacturer's recommendations. DO NOT OVERTIGHTEN.
- 6 Re-Fit lower Fairing

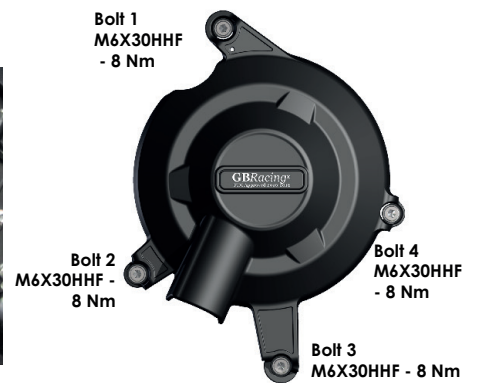
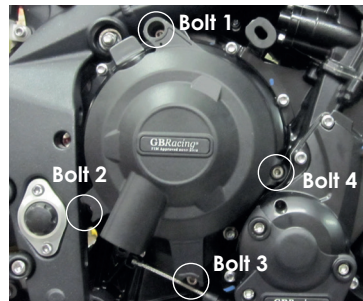

**SECONDARY PULSE COVER PART NO. EC-D675R-2013-3-GBR**

- 1 Remove lower fairing.
- 2 Remove 4 existing bolts from the stock Pulse cover, shown as position Bolt 1, 2, 3 & 4.
- 3 Place the Secondary Pulse Cover over the stock cover.
- 4 Assemble 4 replacement bolts loosely in the correct position as shown.
- 5 Tighten bolts to a Torque of 8 Nm as per Manufacturer's recommendations. DO NOT OVERTIGHTEN.

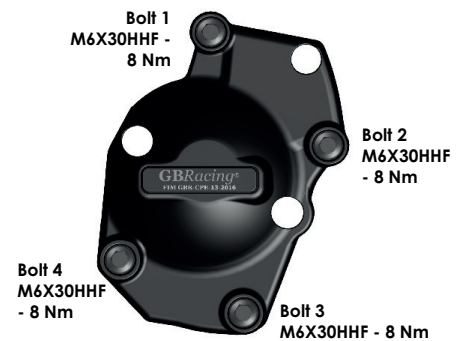
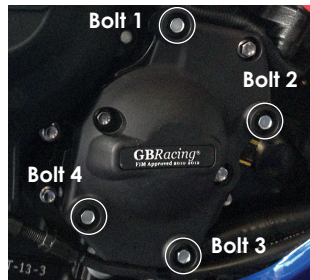

**Bullet Frame Slider Set - RACE - D675R 2013-2016 Model ONLY - Part No. FS-675-2013-R**

**BULLET FRAME SLIDER SET - FS-675-2013-LHS-R - LEFT HAND SIDE - RACE**

- 1 Remove front fairing.
- 2 Remove front engine mount bolt.
- 3 Assemble bolt through the aluminium bush into correct position.
- 4 Tighten to 25Nm torque.
- 5 Slide bullet moulding onto aluminium bush.
- 6 Screw M6 bolt into front of bullet moulding hand tight.
- 7 Replace fairing.



**BULLET FRAME SLIDER SET - FS-675-2013-RHS-R - RIGHT HAND SIDE - RACE**

- 1 Remove front fairing.
- 2 Remove front engine mount bolt.
- 3 Assemble bolt through the aluminium bush into correct position.
- 4 Tighten to 25Nm torque.
- 5 Slide bullet moulding onto aluminium bush.
- 6 Screw M6 bolt into front of bullet moulding hand tight.
- 7 Replace fairing.

