

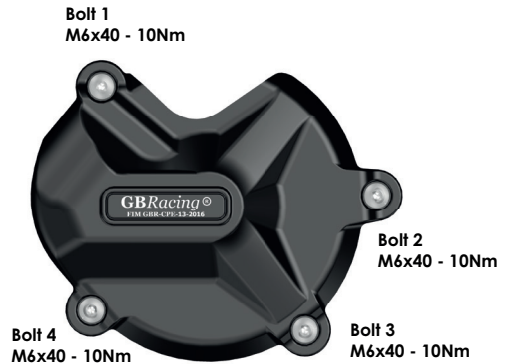

SECONDARY ALTERNATOR COVER – PART NO. EC-S1000RR-2009-1-GBR

- 1 Remove 4 existing stretch bolts from the stock Alternator cover, shown as position Bolt 1, 2, 3 & 4.
- 2 Place the Secondary Alternator Cover over the stock cover.
- 3 Assemble 4 replacement stainless steel M6X40 TORX bolts loosely in the correct position as shown.
- 4 Tighten bolts to a Torque of 10Nm. DO NOT OVERTIGHTEN.

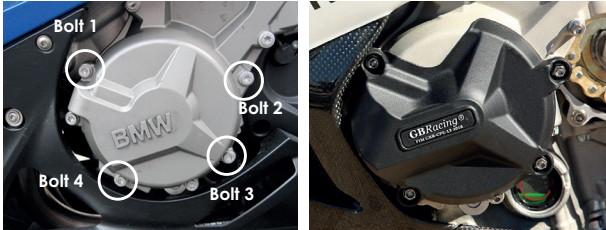

SECONDARY CLUTCH COVER – PART NO. EC-S1000RR-2009-2-GBR

- 1 Remove Upper fairing.
- 2 Remove 3 existing bolts from the stock clutch cover, shown as position Bolt 1, 2 & 3.
- 3 Place the Secondary Clutch Cover over the stock cover.
- 4 Assemble 3 replacement M6X40 TORX bolts, loosely in the correct position as shown.
- 5 Tighten bolts to a Torque of 10Nm. DO NOT OVERTIGHTEN.
- 6 Re-Fit Upper Fairing.

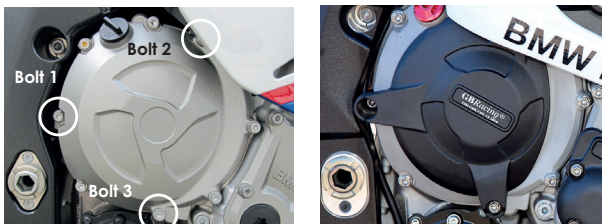

SECONDARY PULSE COVER – PART NO. EC-S1000RR-2009-3-GBR

- 1 Remove 4 existing bolts from the stock pulse cover, shown as position Bolts 1, 2, 3 & 4.
- 2 Place the Secondary Pulse Cover over the stock cover.
- 3 Assemble 4 replacement M6X30 TORX bolts, loosely in the correct position as shown.
- 4 Tighten bolts to a Torque of 10Nm (for Bolt 2 please hand tighten). DO NOT OVERTIGHTEN.

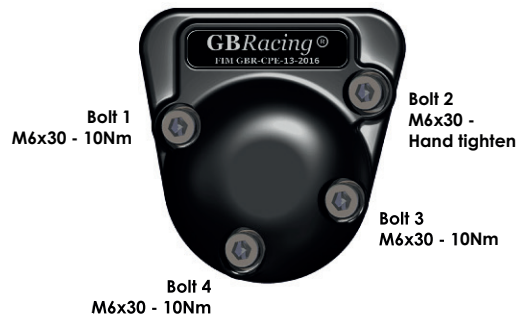
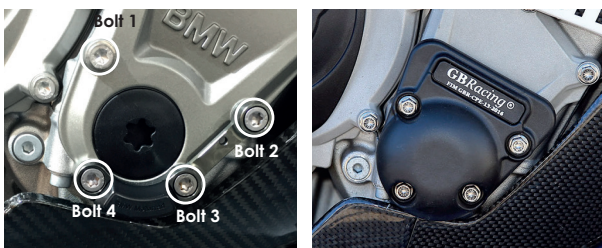

SECONDARY WATER PUMP COVER – PART NO. EC-S1000RR-2009-5-GBR

- 1 Fitting requires a COLD engine.
- 2 Decompress the system before loosening existing stock bolts.
- 3 Have all 3 Replacement Bolts to hand before removing existing stock bolts.
- 4 Loosen bottom fairing bolt to enable access to the Water Pump.
- 5 Remove 3 existing bolts from the stock water pump cover, shown as position Bolts 1, 2, & 3
- 6 Place the Secondary Water Pump Cover over the stock cover.
- 7 Assemble 3 replacement bolts, loosely in the correct position as shown.
- 8 Tighten bolts to a Torque of 10Nm. DO NOT OVERTIGHTEN.
- 9 Tighten bottom fairing bolt.
- 10 Check coolant level & top up if necessary before starting engine.

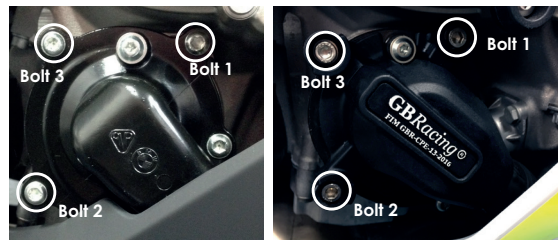



S1000RR 2009-2016

FITTING INSTRUCTIONS

TO BE FITTED BY A QUALIFIED TECHNICIAN



INSTRUCTIONS FOR THESE PARTS:

- 1 Remove upper engine mounting bolt, located through the fairing opening.
- 2 Assemble bolt through the aluminium bush into correct position.
- 3 Tighten to 40NM torque.
- 4 Slide bullet moulding onto aluminium bush.
- 5 Screw M6 bolt into front of bullet moulding hand tight.

BULLET FRAME SLIDER - LEFT HAND SIDE - STREET PART NO. FS-S1000RR-2009-LHS-S



BULLET FRAME SLIDER - RIGHT HAND SIDE - STREET PART NO. FS-S1000RR-2009-RHS-S



BULLET FRAME SLIDER - LEFT HAND SIDE - RACE PART NO. FS-S1000RR-2009-LHS-R



BULLET FRAME SLIDER - RIGHT HAND SIDE - RACE PART NO. FS-S1000RR-2009-RHS-R



www.GBRacing.eu

Protection Bundle RACE: CP-S1000RR-2009-R-CS-GBR: EC-S1000RR-2009-1-GBR, EC-S1000RR-2009-2-GBR, EC-S1000RR-2009-3-GBR, CGA11-GBR, BA12-8-GBR-SET, FS-S1000RR-2009-R

Protection Bundle CP-S1000RR-2009-CS-GBR: EC-S1000RR-2009-1-GBR, EC-S1000RR-2009-2-GBR, EC-S1000RR-2009-3-GBR, CGA11-GBR, BA12-8-GBR-SET, FS-S1000RR-2009-S

Engine Cover Set: EC-S1000RR-2009-SET-GBR: EC-S1000RR-2009-1-GBR, EC-S1000RR-2009-2-GBR, EC-S1000RR-2009-3-GBR

DO NOT use these products unless you agree to our Terms & Conditions, as shown on our paperwork and website. If you do not agree, please return the product(s) to your dealer for a refund.