

THIS SHEET INCLUDES FITTING INSTRUCTIONS FOR THE FOLLOWING PARTS:

Secondary Alternator Cover Part No. EC-CB750-2023-1-GBR / Secondary Clutch Cover Part No. EC-CB750-2023-2-GBR /

Secondary Pulse Cover Part No. EC-CB750-2023-3-GBR

SECONDARY ALTERNATOR COVER
PART NO. EC-CB750-2023-1-GBR

- 1 Ensure engine is cold.
- 2 Remove 4 existing bolts from the stock alternator cover, shown as position Bolt 1, 2, 3 & 4.
Note: When removing Bolt 4, a small amount of water will leak out. See Fig.1
- 2 Place the secondary alternator cover over the stock cover.
- 3 Assemble 4 replacement bolts loosely in the correct positions as shown.
- 4 Tighten bolts to a Torque of 10Nm as per Manufacturer's recommendations in this order: Bolt 4, Bolt 2, Bolt 3 & finally Bolt 1.

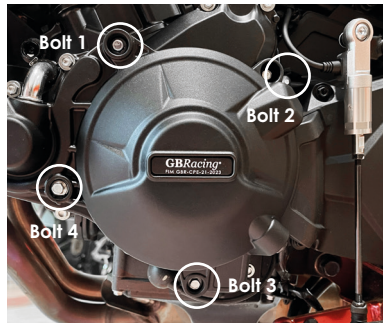
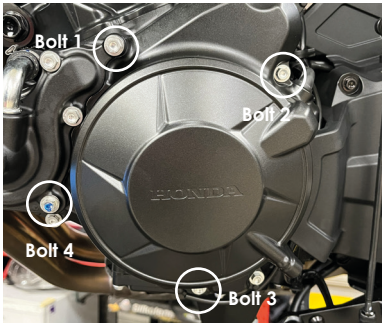

SECONDARY CLUTCH COVER
PART NO. EC-CB750-2023-2-GBR

- 1 Remove 4 existing bolts from the stock clutch cover, shown as position Bolt 1, 2, 3 & 4.
- 2 Place the secondary clutch cover over the stock cover.
- 3 Assemble 4 replacement bolts loosely in the correct positions as shown.
- 4 Tighten bolts to a Torque of 10Nm as per Manufacturer's recommendations.
 DO NOT OVERTIGHTEN.

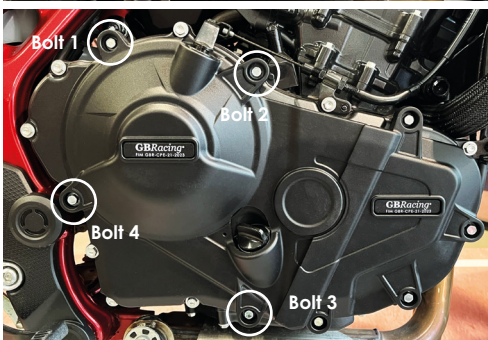
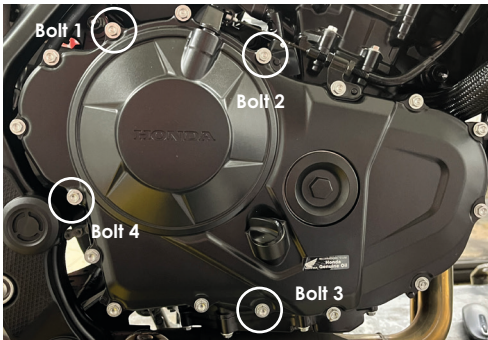

SECONDARY PULSE COVER
PART NO. EC-CB750-2023-3-GBR

- 1 Remove 4 existing bolts from the stock pulse cover, shown as position Bolt 1, 2, 3 & 4.
- 2 Place the secondary pulse cover over the stock cover.
- 3 Assemble 4 replacement bolts loosely in the correct positions as shown.
- 4 Tighten bolts to a Torque of 10Nm as per Manufacturer's recommendations.
DO NOT OVERTIGHTEN.

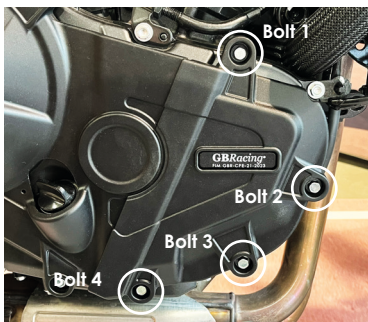
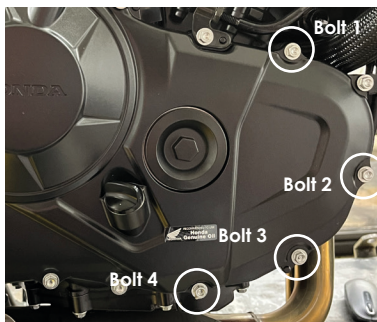

Engine Cover Set: EC-CB750-2023-SET-GBR:

EC-CB750-2023-1-GBR, EC-CB750-2023-2-GBR, EC-CB750-2023-3-GBR