

FITTING INSTRUCTIONS

TO BE FITTED BY A QUALIFIED TECHNICIAN

CLUTCH LEVER GUARDS FOR AFTERMARKET BARS



PART NUMBERS INCLUDED ON THIS SHEET:

CLG-14-A160-GBR / CLG-16-A160-GBR / CLG-16-14-A160-GBR / CLG-18-A160-GBR

CLG-A160 (moulded part only)

CLUTCH LEVER GUARD WITH 14mm INSERT (Fits tube inside diameters from 13.6mm to 15.7mm)

PART NO. CLG-14-A160-GBR

- 1 Remove existing bar end and replace with supplied bar end.
- 2 Tighten bolt until the lever protector is tight and does not move up or down under normal pressure.
- 3 Do not ride if you are unsure if it is tight enough and always get a trained technician to confirm.

Please note: We recommend to use a medium thread lock (not supplied) for correct operation.

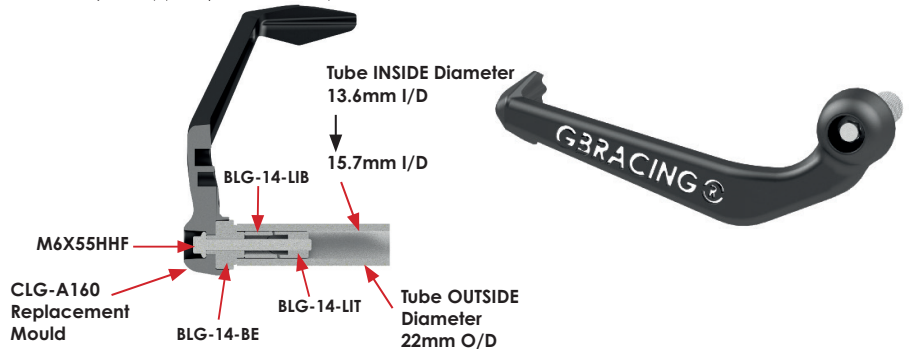

CLUTCH LEVER GUARD WITH 16mm INSERT (Fits tube inside diameters from 15.8mm to 17.9mm)

PART NO. CLG-16-A160-GBR

- 1 Remove existing bar end and replace with supplied bar end.
- 2 Tighten bolt until the lever protector is tight and does not move up or down under normal pressure.
- 3 Do not ride if you are unsure if it is tight enough and always get a trained technician to confirm.

Please note: We recommend to use a medium thread lock (not supplied) for correct operation.



CLUTCH LEVER GUARD WITH 16mm BAR END WITH A 14mm INSERT

PART NO. CLG-16-14-A160-GBR (Fits tube inside diameters from 15.8mm to 16.5mm with a smaller stepped internal diameter of 13.6-15.7mm)

- 1 Remove existing bar end and replace with supplied bar end.
- 2 Tighten bolt until the lever protector is tight and does not move up or down under normal pressure.
- 3 Do not ride if you are unsure if it is tight enough and always get a trained technician to confirm.

Please note: We recommend to use a medium thread lock (not supplied) for correct operation.

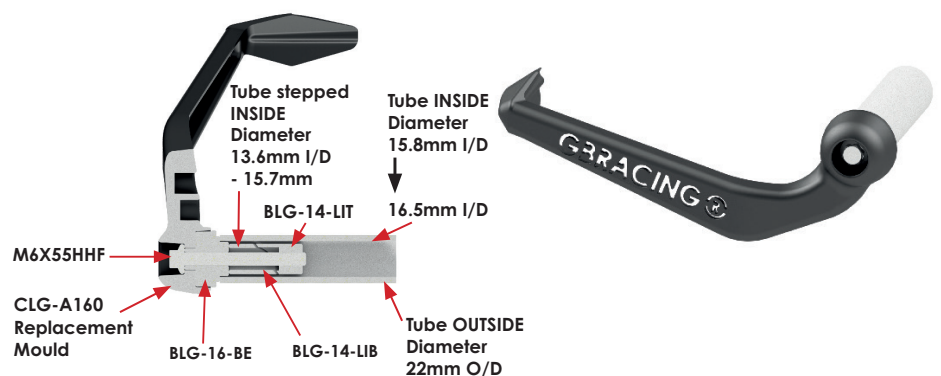

FITTING INSTRUCTIONS

TO BE FITTED BY A QUALIFIED TECHNICIAN

CLUTCH LEVER GUARD WITH 18mm INSERT (Fits tube inside diameters from 18mm to 20mm) PART NO. CLG-18-A160-GBR

- 1 Remove existing bar end and replace with supplied bar end.
- 2 Tighten bolt until the lever protector is tight and does not move up or down under normal pressure.
- 3 Do not ride if you are unsure if it is tight enough and always get a trained technician to confirm.

Please note: We recommend to use a medium thread lock (not supplied) for correct operation.

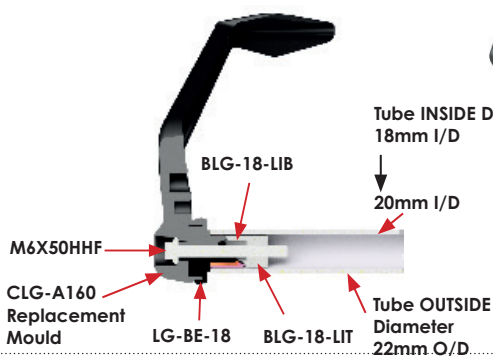

CLUTCH LEVER GUARD, A160 MOULDED REPLACEMENT PART ONLY PART NO. CLG-A160

This is to be used with the GBRacing bar end and insert

- 1 Remove existing bar end and replacing it with supplied bar end.
- 2 Tighten bolt until the lever protector is tight and does not move up or down under normal pressure.
- 3 Do not ride if you are unsure if it is tight enough and always get a trained technician to confirm.



CLUTCH LEVER GUARD, A140 MOULDED REPLACEMENT PART ONLY PART NO. CLG-A140

This is to be used with the GBRacing bar end and insert

- 1 Remove existing bar end and replacing it with supplied bar end.
- 2 Tighten bolt until the lever protector is tight and does not move up or down under normal pressure.
- 3 Do not ride if you are unsure if it is tight enough and always get a trained technician to confirm.

