

THIS SHEET INCLUDES FITTING INSTRUCTIONS FOR THE FOLLOWING PARTS:

Secondary Alternator Cover Part No. EC-RS660-2021-1-GBR / Secondary Clutch Cover Part No. EC-RS660-2021-2-GBR /
 Secondary Water Pump Cover Part No. EC-RS660-2021-5-GBR

SECONDARY ALTERNATOR COVER
PART NO. EC-RS660-2021-1-GBR

- 1 Remove / loosen lower fairing or belly pan.
 - 2 Remove 4 existing bolts from the stock alternator cover, shown as position bolts 1, 2, 3 & 4.
 - 3 Place the secondary alternator cover over the stock cover.
 - 4 Assemble 4 replacement bolts loosely in the correct position as shown.
 - 5 Tighten bolts to a Torque of 12Nm as per Manufacturer's recommendations.
 - 6 Replace / tighten lower fairing or belly pan.
- DO NOT OVERTIGHTEN.

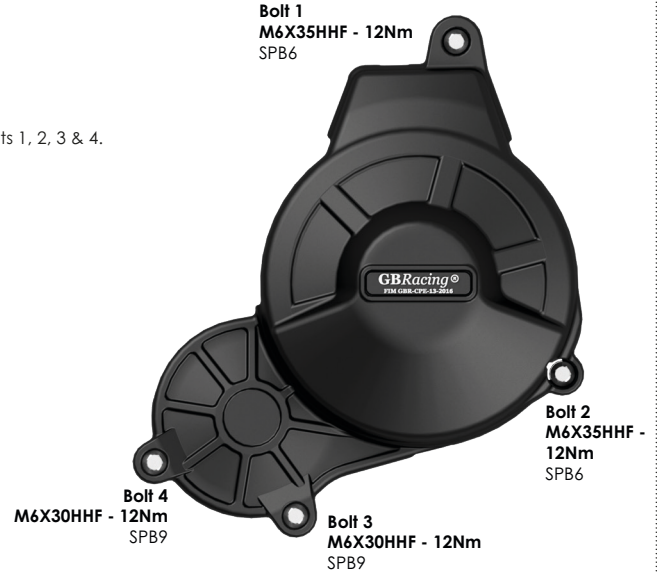
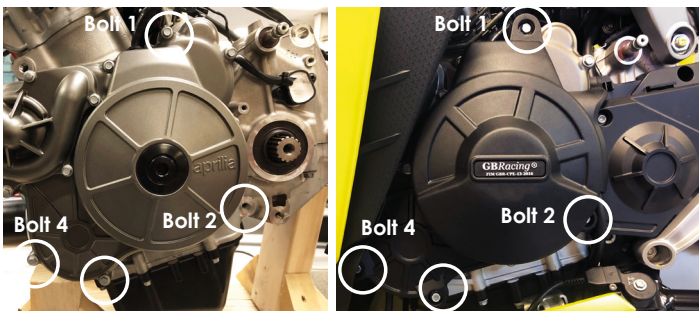

SECONDARY CLUTCH COVER
PART NO. EC-RS660-2021-2-GBR

- 1 Remove 4 existing bolts from the stock clutch cover, shown as position bolts 1, 2, 3 & 4.
 - 2 Place the secondary clutch cover over the stock cover.
 - 3 Assemble 4 replacement bolts loosely in the correct position as shown
 - 4 Tighten bolts to a Torque of 12Nm as per Manufacturer's recommendations.
- DO NOT OVERTIGHTEN.

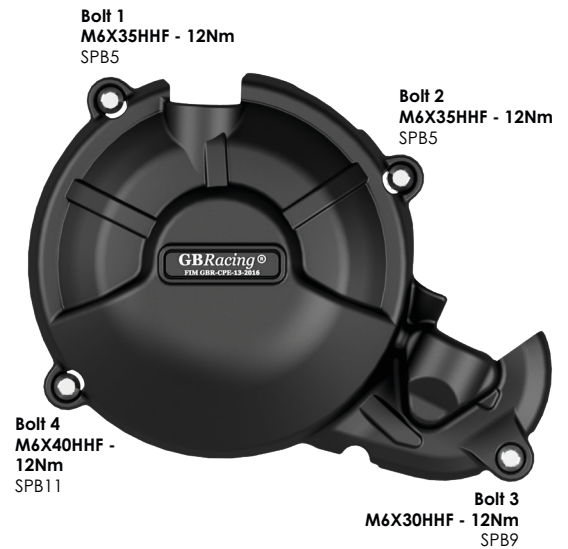
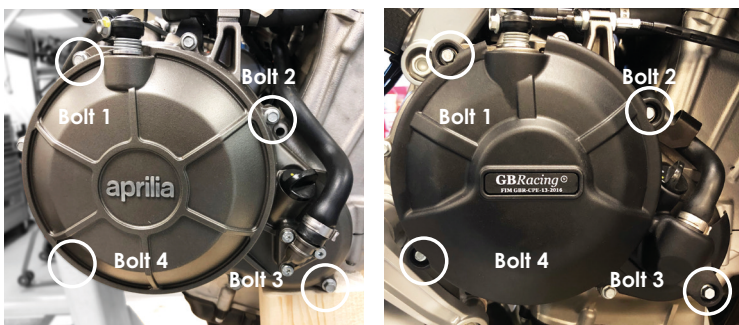

FITMENT ON TUAREG 660 MODEL:

In order to fit the secondary clutch cover:

- 1 Remove the plastic chassis cover before fitting the clutch cover and reinstall after. **See FIG 1.**
- 2 Remove the top bolt of the exhaust guard to allow the guard to drop forward to allow fitment of the clutch cover. **See FIG 2.**

FIG 1: Plastic chassis cover

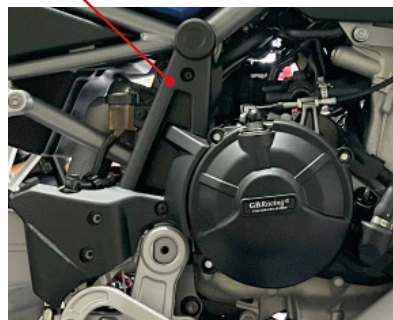

FIG 2:



SECONDARY WATER PUMP COVER
PART NO. EC-RS660-2021-5-GBR

Please Note: Only fit with a cold engine. Leave radiator cap on to reduce fluid loss – you will lose fluid.

- 1 Remove fairing.
- 2 Remove the 3 existing bolts from the stock water pump cover in this order:
 Bolt 1, 3 and then Bolt 2 – Bolt 2 last as this is the drain bolt.
- 3 Place the Secondary water pump cover over the stock cover.
- 4 Replace Bolt 2 first limiting fluid loss: Assemble the bolt loosely in the correct position as shown using the two supplied copper washers - see **Fig.1 for Bolt position 2**
- 5 Assemble the remaining two replacement Bolts 1 & 3 loosely in the correct position as shown
- 6 Tighten bolts to a Torque of 12Nm as per Manufacturer's recommendations.
 DO NOT OVERTIGHTEN.
- 7 Replace fairing and check coolant level.

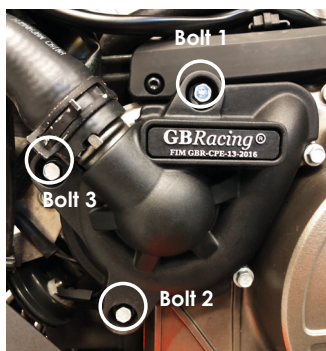
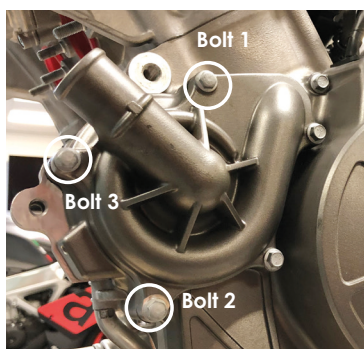

Bolt 1
 M6X50HHF - 12Nm
 SPB2

Bolt 3
 M6X50HHF - 12Nm
 SPB2

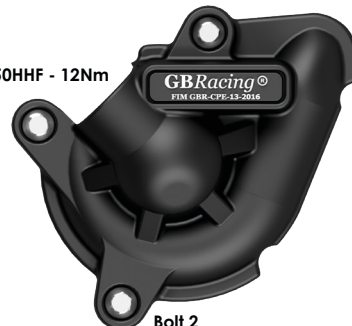

Bolt 2
 M6X50HHF - 12Nm
 SPB2
 + 2 supplied copper washers
 (see Fig.1)

Fig. 1

