



**THIS SHEET INCLUDES FITTING INSTRUCTIONS FOR THE FOLLOWING PARTS:**

Secondary Alternator Cover Part No. EC-S1000RR-2019-1-GBR / Secondary Clutch Cover Part No. EC-S1000RR-2019-2-GBR / Secondary Pulse Cover Part No. EC-S1000RR-2019-3-GBR / Secondary Water Pump Cover Part No. EC-S1000RR-2019-5-GBR / Paddock Stand Bobbins Part No: BA12-8-GBR-SET / Lower Chain Guard Part No. CGA11-GBR / Bullet Frame Sliders Part No. FS-S1000RR-2019-R & FS-S1000RR-2019-S / Frame Protector Set Part No. FP-S1000RR-2019-SET-GBR / Secondary Thermostat Cover Part No. EC-S1000RR-2019-7-GBR (special race part only)

**SECONDARY ALTERNATOR COVER – PART NO. EC-S1000RR-2019-1-GBR**

- 1 Remove 4 existing stretch bolts from the stock Alternator cover, shown as position Bolt 1, 2, 3 & 4.
- 2 Place the Secondary Alternator Cover over the stock cover.
- 3 Assemble 4 replacement stainless steel M6X40A2 TORX bolts loosely in the correct position as shown.
- 4 Tighten bolts to a Torque of 10Nm. DO NOT OVERTIGHTEN.

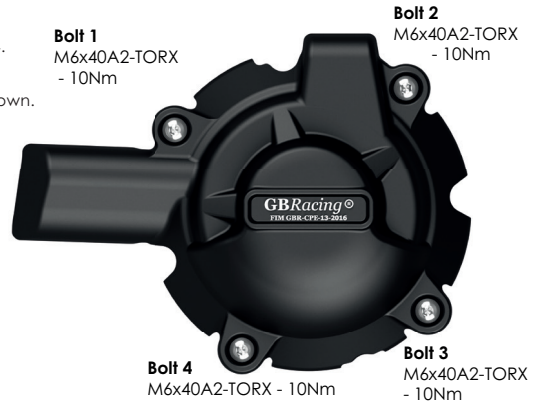
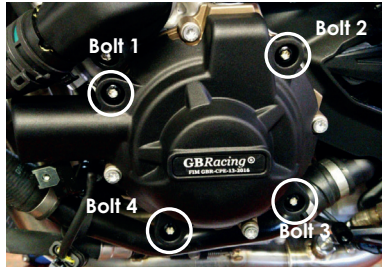
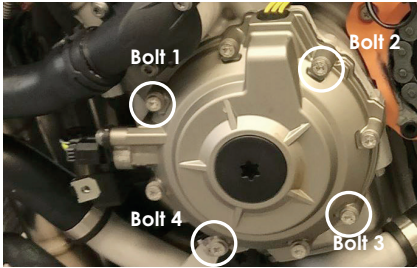

**SECONDARY CLUTCH COVER – PART NO. EC-S1000RR-2019-2-GBR**

- 1 Remove Upper fairing.
- 2 Remove 4 existing bolts from the stock clutch cover, shown as position Bolt 1, 2, 3 & 4.
- 3 Place the Secondary Clutch Cover over the stock cover.
- 4 Assemble 4 replacement M6X40A2 TORX bolts, loosely in the correct position as shown.
- 5 Tighten bolts to a Torque of 10Nm. DO NOT OVERTIGHTEN.
- 6 Re-Fit Upper Fairing.

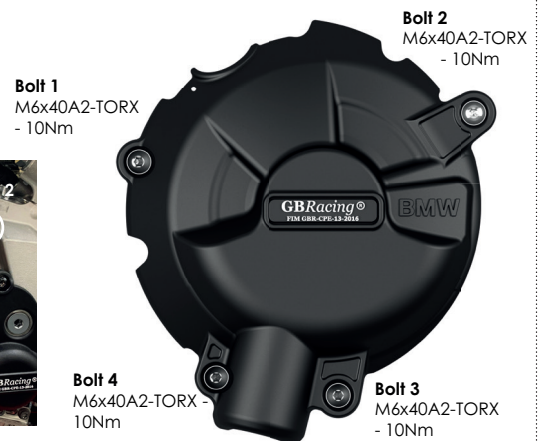
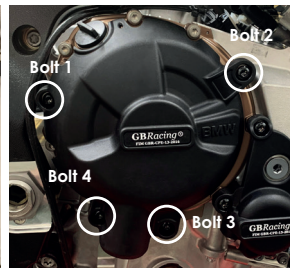
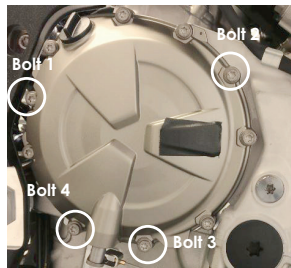

**SECONDARY PULSE COVER – PART NO. EC-S1000RR-2019-3-GBR**

- 1 Remove 3 existing bolts indicated in Fig 1.
- 2 Fit GBRacing fixing bracket to existing bracket as shown in Fig 2.
- 3 Fixing bracket is fitted to engine using existing clutch cable mount.
- 4 Place the Secondary Pulse Cover over these bolt positions in Fig 1.
- 5 Assemble 2 replacement M6X40A2 TORX bolts, loosely in the correct position as shown at bolt positions 1 & 3.
- 6 Bolt 2 M6X30A2 TORX will secure to the fixing bracket as indicated in Fig 2 & 3.
- 7 Tighten bolts to a Torque of 10Nm. DO NOT OVERTIGHTEN.

Fig 1.

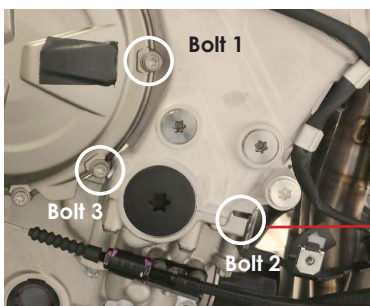
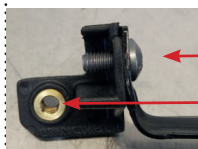

Fig 2.  
Fixing Bracket (EC-S1000RR-2019-3-FB-GBR)  
for Bolt 2



Use OE mounting bolt here  
Bolt 2 M6X30A2 mounting point

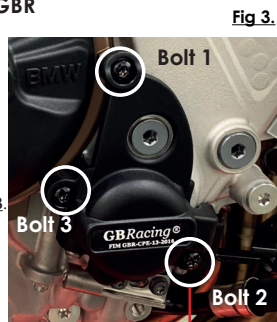
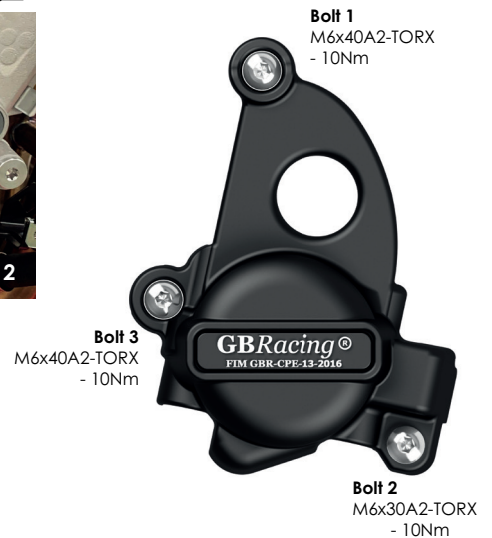

Fig 3.



**ENGINE COVER SET: EC-S1000RR-2019-SET-GBR:**

EC-S1000RR-2019-1-GBR, EC-S1000RR-2019-2-GBR, EC-S1000RR-2019-3-GBR, EC-S1000RR-2019-3-FB-GBR, EC-S1000RR-2019-5-GBR



**S1000RR 2019-2024**

# FITTING INSTRUCTIONS

TO BE FITTED BY A QUALIFIED TECHNICIAN



## SECONDARY WATER PUMP COVER PART NO. EC-S1000RR-2019-5-GBR

- 1 Fitting requires a COLD engine.
- 2 Decompress the system before loosening existing stock bolts.
- 3 Have all 3 Replacement Bolts to hand before removing existing stock bolts.
- 4 Loosen bottom fairing bolt to enable access to the Water Pump.
- 5 Remove 3 existing bolts from the stock water pump cover shown as bolt positions 1, 2 & 3
- 6 Place the Secondary Water Pump Cover over the stock cover.
- 7 Assemble 3 replacement bolts, loosely in the correct position as shown.
- 8 Tighten bolts to a Torque of 10Nm. **DO NOT OVERTIGHTEN.**
- 9 Tighten bottom fairing bolt.
- 10 Check coolant level & top up if necessary before starting engine.

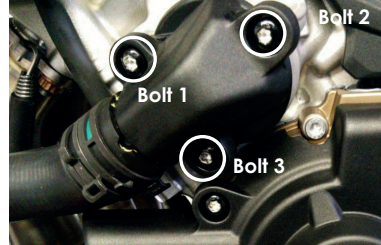

**Bolt 1**  
M6X30A2-TORX  
- 10Nm

**Bolt 2**  
M6X30A2-TORX  
- 10Nm

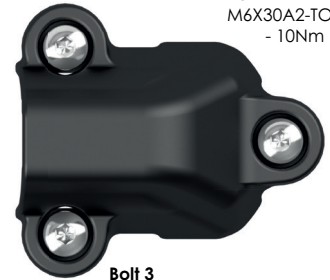

**Bolt 3**  
M6X30A2-TORX  
- 10Nm

## **BULLET FRAME SLIDER SET - RACE:** **PART NO. FS-S1000RR-2019-R:**

- 1 Remove fairing.
- 2 Remove Front Engine mount Bolt.
- 3 Assemble bolt through the aluminium bush into correct position.
- 4 Depending on Year check before Drilling Fairing.
- 5 Tighten to 40Nm torque.
- 6 Replace fairing.
- 7 Slide bullet moulding onto aluminium bush.

## **LEFT HAND SIDE - RACE** **PART NO. FS-S1000RR-2019-LHS-R**



CPM-3

CPB-10-20

M10x55



## **RIGHT HAND SIDE - RACE** **PART NO. FS-S1000RR-2019-RHS-R**



CPM-3

CPB-10-15

M10x55



## **BULLET FRAME SLIDER SET - STREET:** **PART NO. FS-S1000RR-2019-S:**

- 1 Remove fairing.
- 2 Remove Front Engine mount Bolt.
- 3 Assemble bolt through the aluminium bush into correct position.
- 4 Depending on Year check before Drilling Fairing.
- 5 Tighten to 40Nm torque.
- 6 Replace fairing.
- 7 Slide bullet moulding onto aluminium bush.

## **LEFT HAND SIDE - STREET** **PART NO. FS-S1000RR-2019-LHS-S**

CPM-3

CPB-10-40

M10x55



## **RIGHT HAND SIDE - STREET** **PART NO. FS-S1000RR-2019-RHS-S**

CPM-3

CPB-10-35

M10x55



## **PADDOCK STAND / BOBBIN SET - PART NO. BA12-8-GBR-SET**

- 1 Assemble M8 x 40mm Bolt through the moulded bobbin.
- 2 Tighten bolts to swing arm boss, 8 Nm. **DO NOT OVERTIGHTEN**



1 x M8 x 40 Bolt



1 x Moulded Paddock Stand / Bobbin

## **LOWER CHAIN GUARD PART NO. CGA11-GBR**

- 1 Assemble 2 bolts and washers through the lower chain guard into the Black Anodised aluminium mounting block CGA11-B.
- 2 Position the assembly underneath the swing arm, closing the gap to the rear sprocket. Note : There should be a 5mm minimum gap from the bike chain to the lower chain guard. Mark off the chosen hole positions.
- 3 Drill & Tap the marked holes , M6 - (Drill 5mm Dia. for tapping)
- 4 Disassemble the Black Anodised block from the assembly, and mount the block to the underside of the swing arm using the remaining 2 bolts and washers.
- 5 Re-assemble the lower chain guard to the fixed bracket.



2 x Bolts & Washers  
M6x20 - 10Nm





**S1000RR 2019-2024**

# FITTING INSTRUCTIONS

TO BE FITTED BY A QUALIFIED TECHNICIAN



**FRAME PROTECTOR SET: PART NO. FP-S1000RR-2019-SET-GBR:**

**LEFT HAND SIDE FRAME PROTECTOR  
PART NO. FP-S1000RR-2019-LHS-GBR**

- 1 Remove fairing.
- 2 Hold left hand frame protector in correct position and mark chassis.
- 3 Drill and tap chassis in correct locations.
- 4 Mount frame protector.
- 5 Replace fairing.



**RIGHT HAND SIDE FRAME PROTECTOR  
PART NO. FP-S1000RR-2019-RHS-GBR**

- 1 Remove fairing.
- 2 Drill and tap chassis in correct locations IF REQUIRED.
- 3 Fix frame protector to chassis.
- 3 Replace fairing.



***SPECIAL RACE PART ONLY - NOT TO FIT ON A ROAD BIKE (No bolts supplied)***

**SECONDARY THERMOSTAT COVER PART NO. EC-S1000RR-2019-7-GBR**

- 1 Fitting requires a COLD engine.
- 2 Decompress the system before loosening existing stock bolts.
- 3 Have all 3 Replacement Bolts to hand (bolts not supplied) before removing existing stock bolts.
- 4 Loosen bottom fairing bolt to enable access to the thermostat cover.
- 5 Remove 3 existing bolts from the thermostat cover shown as bolt positions 1, 2 & 3
- 6 Place the thermostat cover over the stock cover.
- 7 Assemble 3 replacement bolts (not supplied), loosely in the correct position as shown.
- 8 Tighten bolts to a Torque of 10Nm.  
DO NOT OVERTIGHTEN.
- 9 Tighten bottom fairing bolt.
- 10 Check coolant level & top up if necessary before starting engine.

**Bolt Length required: 3 x 30mm - 10Nm**  
(Bolts not supplied)

