



**F900R, XR, GS, GSA 2020+
F800 GS 2024
F850 GS 2019-2024
F750 GS 2019-2024**

FITTING INSTRUCTIONS

TO BE FITTED BY A QUALIFIED TECHNICIAN



THIS SHEET INCLUDES FITTING INSTRUCTIONS FOR THE FOLLOWING PARTS:

Secondary Alternator Cover Part No. EC-F900R-2020-1-GBR / Secondary Clutch Cover Part No. EC-F900R-2020-2-GBR /
Secondary Water Pump Cover Part No. EC-F900R-2020-5-GBR /

SECONDARY ALTERNATOR COVER – PART NO. EC-F900R-2020-1-GBR

- 1 Remove 4 existing bolts from the stock alternator cover, shown as position Bolt 1, 2, 3 & 4.
 - 2 Place the secondary alternator cover over the stock cover.
 - 3 Assemble 4 replacement M7X45-TORX bolts loosely in the correct position as shown.
 - 4 Tighten bolts to a torque of 20Nm. **DO NOT OVERTIGHTEN.**
- NOTE:** When fitting to model with engine bars (GS Adventure) the alternator side bars will need to be removed for fitting, then they can be re fitted.

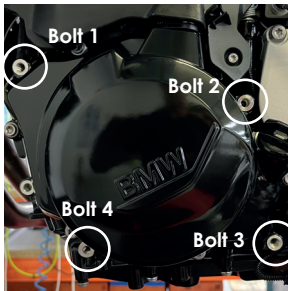

Bolt 1
SPB-20
M7x45-TORX
- 20Nm

Bolt 2
SPB-20
M7x45-TORX
- 20Nm

Bolt 4
SPB-20
M7x45-TORX
- 20Nm

Bolt 3
SPB-20
M7x45-TORX
- 20Nm

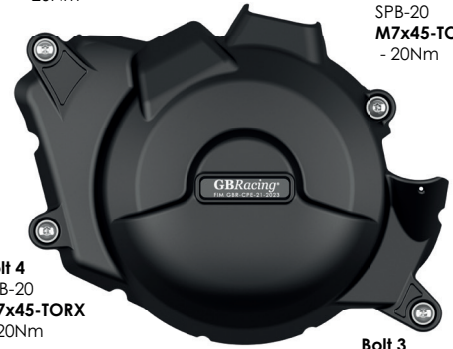

SECONDARY CLUTCH COVER – PART NO. EC-F900R-2020-2-GBR

- 1 Remove 4 existing bolts from the stock clutch cover, shown as position Bolt 1, 2, 3 & 4.
- NOTE:** Bolt 2 has a rubberised washer and must be reused between the OE casing and GBRacing cover.
- 2 Place the secondary clutch cover over the stock cover.
- 3 Assemble 4 replacement M7X50-TORX bolts loosely in the correct position as shown.
- 4 Tighten bolts to a torque of 20Nm. **DO NOT OVERTIGHTEN.**

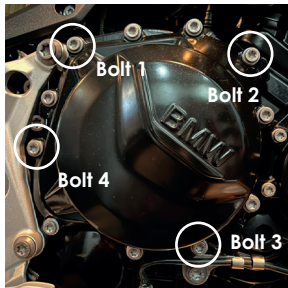

Bolt 1
SPB-20
M7x50-TORX
- 20Nm

Bolt 2
SPB-20
M7x50-TORX
- 20Nm

Bolt 4
SPB-20
M7x50-TORX
- 20Nm

Bolt 3
SPB-20
M7x50-TORX
- 20Nm



SECONDARY WATER PUMP COVER – PART NO. EC-F900R-2020-5-GBR

- 1 Remove 4 existing bolts from the stock water pump cover, shown as position Bolt 1, 2, 3 & 4.
- 2 Place the secondary water pump cover over the stock cover.
- 3 Assemble 4 replacement stainless steel M6X40A2-TORX bolts loosely in the correct position as shown.
- 4 Tighten bolts to a torque of 12Nm. **DO NOT OVERTIGHTEN.**

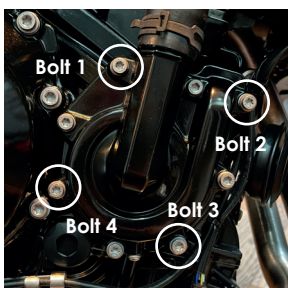

Bolt 1
SPB-3
M6x40A2-TORX
- 12Nm

Bolt 2
SPB-3
M6x40A2-TORX
- 12Nm

Bolt 4
SPB-3
M6x40A2-TORX
- 12Nm

Bolt 3
SPB-3
M6x40A2-TORX
- 12Nm

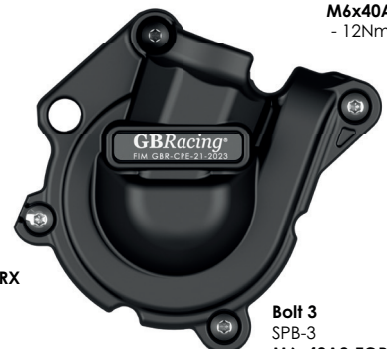

ENGINE COVER SET: EC-F900R-2020-SET-GBR:

EC-F900R-2020-1-GBR, EC-F900R-2020-2-GBR, EC-F900R-2020-5-GBR

**DO NOT use these products unless you agree to our Terms & Conditions, as shown on our paperwork and website.
If you do not agree, please return the product(s) to your dealer for a refund.**