



S 1000 RR 2019-2025
M 1000 RR 2019-2024

FITTING INSTRUCTIONS

TO BE FITTED BY A QUALIFIED TECHNICIAN



THIS SHEET INCLUDES FITTING INSTRUCTIONS FOR THE FOLLOWING PARTS:

Secondary Alternator Cover Part No. EC-S1000RR-2019-1-GBR / Secondary Clutch Cover Part No. EC-S1000RR-2019-2-GBR /
 Secondary Pulse Cover Part No. EC-S1000RR-2019-3-GBR / Secondary Thermostat Cover Part No. EC-S1000RR-2019-5-GBR /
 Paddock Stand Bobbins Part No: BA12-8-GBR-SET / Secondary Thermostat Cover Part No. EC-S1000RR-2019-7-GBR (special race part only)
 Bullet Frame Sliders Part No. FS-S1000RR-2019-R & FS-S1000RR-2019-S / Frame Protector Set Part No. FP-S1000RR-2019-SET-GBR /

SECONDARY ALTERNATOR COVER – PART NO. EC-S1000RR-2019-1-GBR

- 1 Remove 4 existing stretch bolts from the stock Alternator cover, shown as position Bolt 1, 2, 3 & 4.
- 2 Place the Secondary Alternator Cover over the stock cover.
- 3 Assemble 4 replacement stainless steel M6X40A2 TORX bolts loosely in the correct position as shown.
- 4 Tighten bolts to a Torque of 10Nm. DO NOT OVERTIGHTEN.

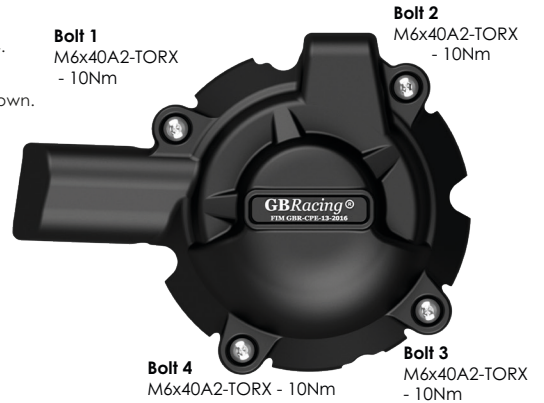
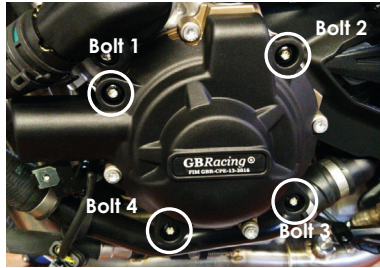
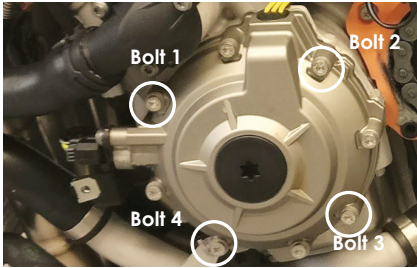

SECONDARY CLUTCH COVER – PART NO. EC-S1000RR-2019-2-GBR

- 1 Remove Upper fairing.
- 2 Remove 4 existing bolts from the stock clutch cover, shown as position Bolt 1, 2, 3 & 4.
- 3 Place the Secondary Clutch Cover over the stock cover.
- 4 Assemble 4 replacement M6X40A2 TORX bolts, loosely in the correct position as shown.
- 5 Tighten bolts to a Torque of 10Nm. DO NOT OVERTIGHTEN.
- 6 Re-Fit Upper Fairing.

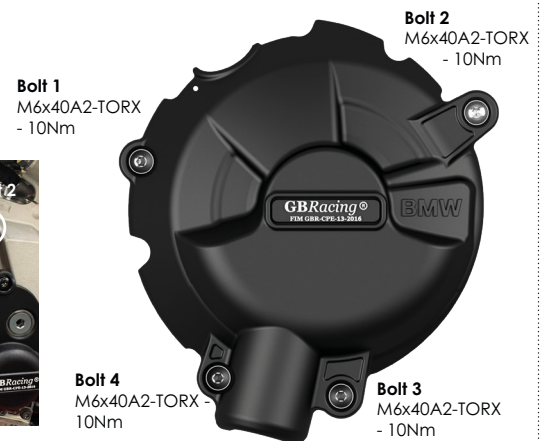
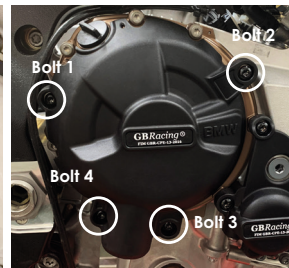
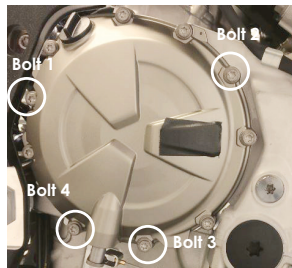

SECONDARY PULSE COVER – PART NO. EC-S1000RR-2019-3-GBR

- 1 Remove 3 existing bolts indicated in **Fig 1**.
- 2 Fit GBRacing fixing bracket to existing bracket as shown in **Fig 2**.
- 3 Fixing bracket is fitted to engine using existing clutch cable mount.
- 4 Place the Secondary Pulse Cover over these bolt positions in **Fig 1**.
- 5 Assemble 2 replacement M6X40A2 TORX bolts, loosely in the correct position as shown at bolt positions 1 & 3.
- 6 Bolt 2 M6X30A2 TORX will secure to the fixing bracket as indicated in **Fig 2 & 3**.
- 7 Tighten bolts to a Torque of 10Nm. DO NOT OVERTIGHTEN.

Fig 1.

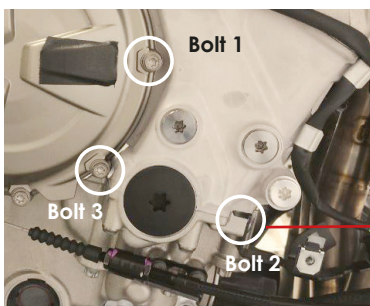
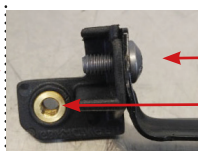

Fig 2.
Fixing Bracket (EC-S1000RR-2019-3-FB-GBR) for Bolt 2



Use OE mounting bolt here

Bolt 2 M6X30A2 mounting point

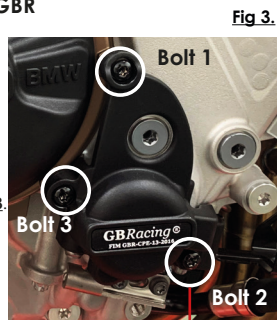
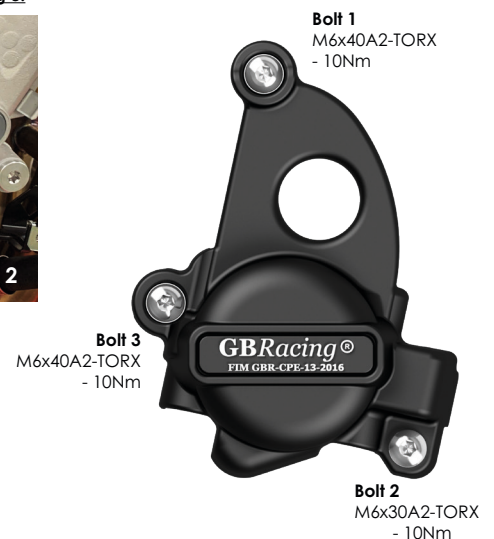

Fig 3.



ENGINE COVER SET: EC-S1000RR-2019-SET-GBR:

EC-S1000RR-2019-1-GBR, EC-S1000RR-2019-2-GBR, EC-S1000RR-2019-3-GBR, EC-S1000RR-2019-3-FB-GBR, EC-S1000RR-2019-5-GBR



S 1000 RR 2019-2025
M 1000 RR 2019-2024

FITTING INSTRUCTIONS

TO BE FITTED BY A QUALIFIED TECHNICIAN



SECONDARY THERMOSTAT COVER PART NO. EC-S1000RR-2019-5-GBR

- 1 Fitting requires a COLD engine.
- 2 Decompress the system before loosening existing stock bolts.
- 3 Have all 3 Replacement Bolts to hand before removing existing stock bolts.
- 4 Loosen bottom fairing bolt to enable access to the Thermostat Cover.
- 5 Remove 3 existing bolts from the stock Thermostat Cover shown as bolt positions 1, 2 & 3
- 6 Place the Thermostat Cover over the stock cover.
- 7 Assemble 3 replacement bolts, loosely in the correct position as shown.
- 8 Tighten bolts to a Torque of 10Nm. **DO NOT OVERTIGHTEN.**
- 9 Tighten bottom fairing bolt.
- 10 Check coolant level & top up if necessary before starting engine.

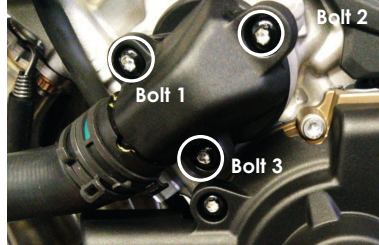

Bolt 1
M6X30A2-TORX
- 10Nm

Bolt 2
M6X30A2-TORX
- 10Nm

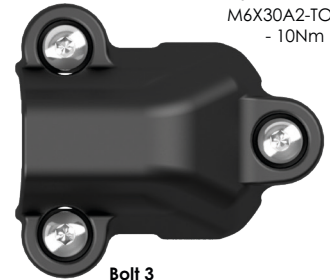

Bolt 3
M6X30A2-TORX
- 10Nm

BULLET FRAME SLIDER SET - RACE: PART NO. FS-S1000RR-2019-R:

- 1 Remove fairing.
- 2 Remove Front Engine mount Bolt.
- 3 Assemble bolt through the aluminium bush into correct position.
- 4 Depending on Year check before Drilling Fairing.
- 5 Tighten to 40Nm torque.
- 6 Replace fairing.
- 7 Slide bullet moulding onto aluminium bush.

LEFT HAND SIDE - RACE PART NO. FS-S1000RR-2019-LHS-R



CPM-3

CPB-10-20

M10x55



RIGHT HAND SIDE - RACE PART NO. FS-S1000RR-2019-RHS-R



CPM-3

CPB-10-15

M10x55



BULLET FRAME SLIDER SET - STREET: PART NO. FS-S1000RR-2019-S:

- 1 Remove fairing.
- 2 Remove Front Engine mount Bolt.
- 3 Assemble bolt through the aluminium bush into correct position.
- 4 Depending on Year check before Drilling Fairing.
- 5 Tighten to 40Nm torque.
- 6 Replace fairing.
- 7 Slide bullet moulding onto aluminium bush.

LEFT HAND SIDE - STREET PART NO. FS-S1000RR-2019-LHS-S

CPM-3

CPB-10-40

M10x55



RIGHT HAND SIDE - STREET PART NO. FS-S1000RR-2019-RHS-S

CPM-3

CPB-10-35

M10x55



PADDOCK STAND / BOBBIN SET - PART NO. BA12-8-GBR-SET

- 1 Assemble M8 x 40mm Bolt through the moulded bobbin.
- 2 Tighten bolts to swing arm boss, 8 Nm. **DO NOT OVERTIGHTEN**



1 x M8 x 40 Bolt



1 x Moulded Paddock
Stand / Bobbin



S 1000 RR 2019-2025
M 1000 RR 2019-2024

FITTING INSTRUCTIONS

TO BE FITTED BY A QUALIFIED TECHNICIAN



FRAME PROTECTOR SET: PART NO. FP-S1000RR-2019-SET-GBR:

LEFT HAND SIDE FRAME PROTECTOR PART NO. FP-S1000RR-2019-LHS-GBR

- 1 Remove fairing.
- 2 Hold left hand frame protector in correct position and mark chassis.
- 3 Drill and tap chassis in correct locations.
- 4 Mount frame protector.
- 5 Replace fairing.



RIGHT HAND SIDE FRAME PROTECTOR PART NO. FP-S1000RR-2019-RHS-GBR

- 1 Remove fairing.
- 2 Drill and tap chassis in correct locations IF REQUIRED.
- 3 Fix frame protector to chassis.
- 3 Replace fairing.



SPECIAL RACE PART ONLY - NOT TO FIT ON A ROAD BIKE (No bolts supplied)

SECONDARY THERMOSTAT COVER PART NO. EC-S1000RR-2019-7-GBR

- 1 Fitting requires a COLD engine.
- 2 Decompress the system before loosening existing stock bolts.
- 3 Have all 3 Replacement Bolts to hand (bolts not supplied) before removing existing stock bolts.
- 4 Loosen bottom fairing bolt to enable access to the thermostat cover.
- 5 Remove 3 existing bolts from the thermostat cover shown as bolt positions 1, 2 & 3
- 6 Place the thermostat cover over the stock cover.
- 7 Assemble 3 replacement bolts (not supplied), loosely in the correct position as shown.
- 8 Tighten bolts to a Torque of 10Nm.
DO NOT OVERTIGHTEN.
- 9 Tighten bottom fairing bolt.
- 10 Check coolant level & top up if necessary before starting engine.

Bolt Length required: 3 x 30mm - 10Nm
(Bolts not supplied)

