

THIS SHEET INCLUDES FITTING INSTRUCTIONS FOR THE FOLLOWING PARTS:

Secondary Alternator Cover Part No. EC-CBR1000-2008-1-GBR / Secondary Alternator Cover - KIT - Part No. EC-CBR1000-2008-1-K-GBR /  
 Secondary Clutch Cover Part No. EC-CBR1000-2008-2-GBR / Secondary Pulse Cover Part No. EC-CBR1000-2008-3-GBR /  
 Bullet Frame Race Slider Set - RACE - Part No. FS-CBR1000-2008-R

**SECONDARY ALTERNATOR COVER PART NO. EC-CBR1000-2008-1-GBR**

Fits 2008-2011 STOCK BIKES with STOCK FAIRINGS & 2008-2016 RACE BIKES with RACE FAIRINGS

- 1 Remove original fairing panel and plastic cover that is fitted over the original alternator cover.
- 2 Remove 4 existing bolts from the stock Alternator cover, shown as position Bolt 1, 2, 3 & 4.
- 3 Place the Secondary Alternator Cover over the stock cover.
- 4 Assemble 4 replacement bolts loosely in the correct position as shown.
- 5 Tighten bolts to a Torque of 10Nm as per Manufacturer's recommendations. DO NOT OVERTIGHTEN.
- 6 Replace original plastic cover and fairing.



**SECONDARY ALTERNATOR COVER - KIT - PART NO. EC-CBR1000-2008-1-K-GBR**

**KIT ONLY**

- 1 Remove 4 existing bolts from the stock Alternator cover, shown as position Bolt 1, 2, 3 & 4.
- 2 For the 2009 onwards. Please remove original plastic Honda cover before fitting your GBRacing engine cover. Once the GBRacing engine cover has been fitted, please replace the original plastic Honda cover on top.
- 3 Assemble 4 replacement bolts loosely in the correct position as shown.
- 4 Tighten bolts to a Torque of 10Nm as per Manufacturer's recommendations. DO NOT OVERTIGHTEN.



**SECONDARY CLUTCH COVER PART NO. EC-CBR1000-2008-2-GBR**

1. Remove fairing.
2. Remove 3 existing bolts from the stock Clutch cover, shown as position Bolt 1, 2 & 3.
3. Place the Secondary Clutch Cover over the stock cover.
4. Loosely assemble bolt 3 first (2-3 turns), then bolts 1 & 2, with the replacement bolts supplied.
5. Tighten bolts to a Torque of 10Nm as per manufacturers recommendations. DO NOT OVERTIGHTEN.

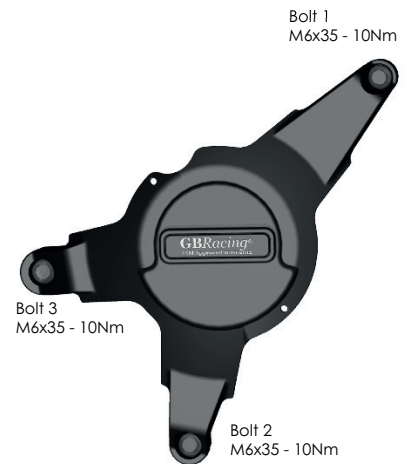
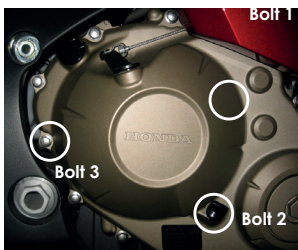

**SECONDARY PULSE COVER PART NO. EC-CBR1000-2008-3-GBR**

1. Remove offside fairing infill panel.
2. Remove 4 existing bolts from the stock Pulse cover, shown as position Bolt 1, 2, 3 & 4. **Note : Bolt 1 has a sealing washer that needs retaining for re-use later.**
3. Assemble one of the replacement bolts through the Secondary Pulse Cover at position 1, then re-assemble the stock sealing washer as shown below.
4. Place the Secondary Pulse Cover over the stock cover.
5. Assemble the remaining 3 replacement bolts loosely in the correct position as shown.
6. Tighten bolts to a Torque of 10Nm as per Manufacturer's recommendations.
7. Refit offside fairing infill panel.



**BULLET FRAME SLIDER - LEFT HAND SIDE - RACE ONLY**  
**PART NO. FS-CBR1000-2008-LHS-R**

**Note: Fairing may require modification**

1. Remove left hand side fairing panel from bike.
2. Remove lower engine / frame mounting bolt.
3. Assemble bolt through the aluminium bush into correct position.

Please note: We recommend copperslip to be used on the thread of our replacement bolt before it is inserted

4. Tighten to 64NM torque.
5. Slide bullet moulding onto aluminium bush.
6. Screw M6 bolt into front of bullet moulding hand tight.
7. Replace left hand side fairing panel.

PLEASE NOTE: These are only sold separately and are not available in our Bundles.



**BULLET FRAME SLIDER - RIGHT HAND SIDE - RACE ONLY**  
**PART NO. FS-CBR1000-2008-RHS-R**

**Note: Fairing may require modification**

1. Remove right hand side fairing panel from bike.
2. Remove lower engine / frame mounting bolt.
3. Assemble bolt through the aluminium bush into correct position.

Please note: We recommend copperslip to be used on the thread of our replacement bolt before it is inserted

4. Tighten to 64NM torque.
5. Slide bullet moulding onto aluminium bush.
6. Screw M6 bolt into front of bullet moulding hand tight.
7. Replace right hand side fairing panel.

PLEASE NOTE: These are only sold separately and are not available in our Bundles.

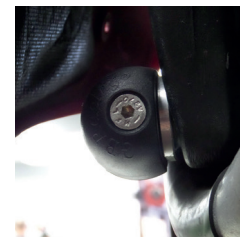
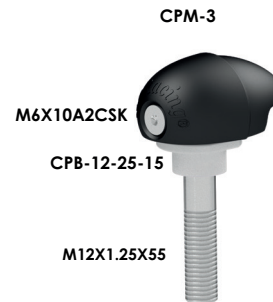

**STOCK MOTORCYCLE PROTECTION BUNDLE 2008-2011 STREET, 2008-2016 RACE - CP-CBR1000-2008-CS-GBR:**

EC-CBR1000-2008-1-GBR, EC-CBR1000-2008-2-GBR, EC-CBR1000-2008-3-GBR, CGA10-GBR, BA12-8-GBR-SET

**RACE KIT MOTORCYCLE PROTECTION BUNDLE 2008 - 2016 - CP-CBR1000-2008-CS-K-GBR:**

EC-CBR1000-2008-1-K-GBR, EC-CBR1000-2008-2-GBR, EC-CBR1000-2008-3-GBR, CGA10-GBR, BA12-8-GBR-SET

**STOCK ENGINE COVER SET 2008-2011 STOCK, 2008-2016 RACE - EC-CBR1000-2008-SET-GBR:** EC-CBR1000-2008-1-GBR, EC-CBR1000-2008-2-GBR, EC-CBR1000-2008-3-GBR

**RACE KIT ENGINE COVER SET - EC-CBR1000-2008-SET-K-GBR:** EC-CBR1000-2008-1-K-GBR, EC-CBR1000-2008-2-GBR, EC-CBR1000-2008-3-GBR

[www.GBRacing.eu](http://www.GBRacing.eu)